

**Important User Information**

This information is for the end user of BiSlide Assemblies. The end user should read this document and retain it for future reference.

**Table of Contents**

Precautions.....1	End Plate Removal...4	Wiring.....6
Terminology.....1	Load Attachment.....4	Convert to Motorized...7
Load Capacity.....2	Lubrication.....5	Limit Switches.....7
Model Numbers.....2	Adjustments.....5	Warranty & CE.....8
Mounting.....3,4	Motor Mounting.....6	Contact Information...8

**⚠ WARNING** Overloading, improper mounting, or misapplication of this product may result in serious injury. Suitability for a particular application of this product resides with the end user.

**⚠ CAUTION** Stay clear of moving parts when operating your BiSlide



**⚠** BiSlide Assemblies must not be used in applications where Operator Error, Mechanical Failure, Knob/Thumb Lock Failure, Motor, Wiring, Controller, or Limit Switch Failure could result in personal injury. If you feel this product is not suitable for your application then, immediately contact your distributor or Velmex to obtain a RMA number to return this product for a refund or credit.

**BiSlide Terminology**

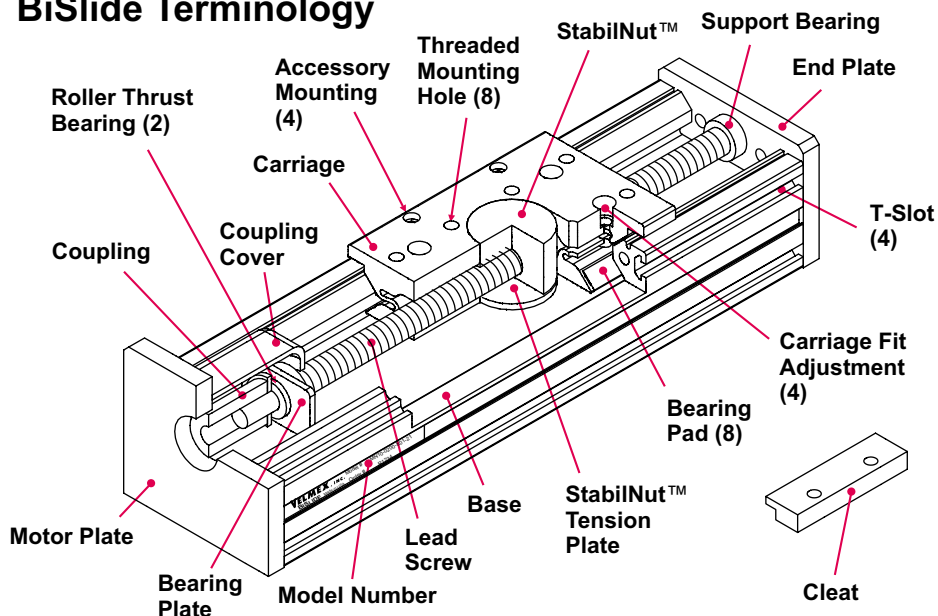

**Maximum Load Capacity**

**⚠ WARNING** Overloading, improper mounting, or misapplication of this product may result in serious injury.

**⚠** Exceeding the load/speed limits shown in the graph at the right will result in rapid Lead Screw and Nut wear. Consult our engineering department for other duty cycles and temperatures.

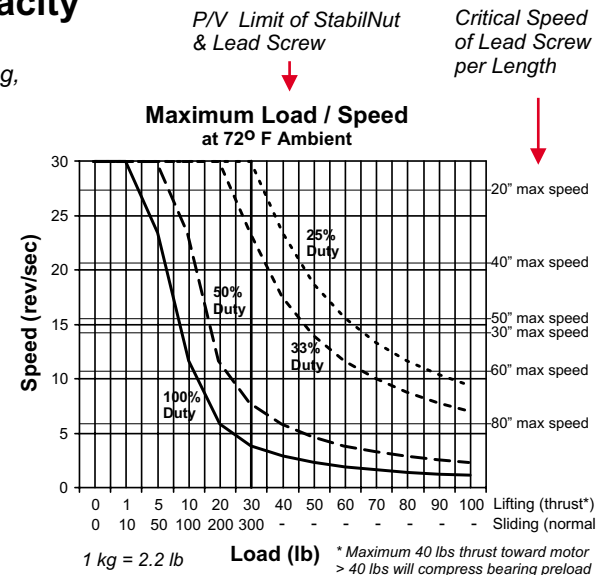
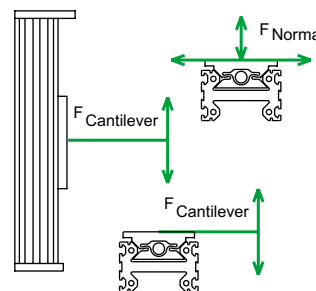
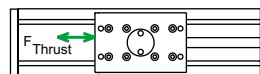

Operating temperature: 0 to 180° F (-18 to 82° C)

Load	Dynamic	Static	Momentary
Normal	300 lb.	300 lb.	1000 lb.
Thrust	100 lb*	200 lb.	300 lb.
Cantilevered**	500 inch-lb. (250 for Way Cover Model)		

\*\* Cantilever load is F x distance from Carriage center. To calculate an equivalent center load use this formula:  $Equal\ Normal\ Load = (d \times L/2) + L$   
d= distance load is from center of Carriage in inches, L= Load (lbs.)

**Model Numbers**

Use the following table to identify the characteristics of your BiSlide. The Model number like the one shown below is located on the side of the BiSlide (see drawing on page 1).

**M N 1 0 - 0 2 0 0 - E 0 1 - 2 1**

<p>Cross Section M</p> <p>Design 10=Inch 11=Inch &amp; Way Cover</p> <p>Drive Scheme N=Nut/Screw Drive F=Free Sliding</p>	<table border="1"> <tr> <th>Lead Screw</th> <th>Advance/Turn</th> </tr> <tr> <td>Blank</td> <td>None</td> </tr> <tr> <td>M02</td> <td>2.00 mm</td> </tr> <tr> <td>E01</td> <td>0.10 inches</td> </tr> <tr> <td>E04</td> <td>0.40 inches</td> </tr> </table> <p>Design Travel* (Tenths of Inches) Standard travel lengths (Inches): 5,10,15,20,30,40,50,60,80</p> <p>* Free Sliding Models have 2.4" Longer Travel, Waycover Models Under 40" Travel have 1.0" less</p>	Lead Screw	Advance/Turn	Blank	None	M02	2.00 mm	E01	0.10 inches	E04	0.40 inches	<p>Mounting Blank =None 11=Basic Knob 12=Knob/Counter, Horizontal, Increment + From Knob 13=Knob/Counter, Vertical, Increment + From Knob ** 14=Knob/Counter, Horizontal, Increment - From Knob ** 15=Knob/Counter, Vertical, Increment - From Knob ** 20=NEMA 23 Motor Mount 21=NEMA 23 Mount &amp; Limit Switches 30=NEMA 34 Motor Mount 31=NEMA 34 Mount &amp; Limit Switches</p> <p>** For BiSlides oriented vertically with the knob up. Use the Horizontal reading (-12 or -14) for applications with the knob down.</p>
Lead Screw	Advance/Turn											
Blank	None											
M02	2.00 mm											
E01	0.10 inches											
E04	0.40 inches											

BISLIDE® Assemblies Owner's Manual

## Mounting to a Surface

The BiSlide Assembly base should be mounted with Velmex MC cleats to a reasonably flat surface. Inaccuracies and binding can result if mounted to non-flat surfaces. Mounting surface should be steel or aluminum and have 1/4-20 UNC threaded holes with a minimum thread depth of 0.30"

Refer to drawing and table below for cleat placement. Use cleats in pairs with a pair 1.2" from each end to first mounting hole. All other cleats should be equally spaced between them. Use more cleats for heavy off center loads and for more rigidity. Attach cleats with Velmex MB-1 bolts or equal grade 8 bolts. Start with bolts finger tight and then tighten bolts progressively alternating sides and diagonals. Finish by tightening bolts to 95 in-lbs. The BiSlide can also be mounted on it's side using bolts or nuts in the T-slots (see illustrations below).  
*Thread locking compound (Loctite™) is recommended for all mounting bolts.*

Design		L		Lighter Loads			Heavier Loads		
Travel (inches)	Travel (cm)	Length (inches)	Length (cm)	# Cleats	Spacing (inches)	Spacing (cm)	# Cleats	Spacing (inches)	Spacing (cm)
5	12.70	12.2	30.988	4	8.380	21.285	4	8.380	21.285
10	25.40	17.2	43.688	4	13.380	33.985	6	6.690	16.993
15	38.10	22.2	56.388	4	18.380	46.685	8	6.127	15.562
20	50.80	27.2	69.088	6	11.690	29.693	10	5.845	14.846
30	76.20	37.2	94.488	8	11.127	28.262	12	6.676	16.957
40	101.60	49.6	125.984	10	11.445	29.070	14	7.630	19.380
50	127.00	59.6	151.384	12	11.156	28.336	16	7.969	20.240
60	152.40	69.6	176.784	14	10.963	27.847	18	8.223	20.885
80	203.20	89.6	227.584	16	12.254	31.126	20	9.531	24.209

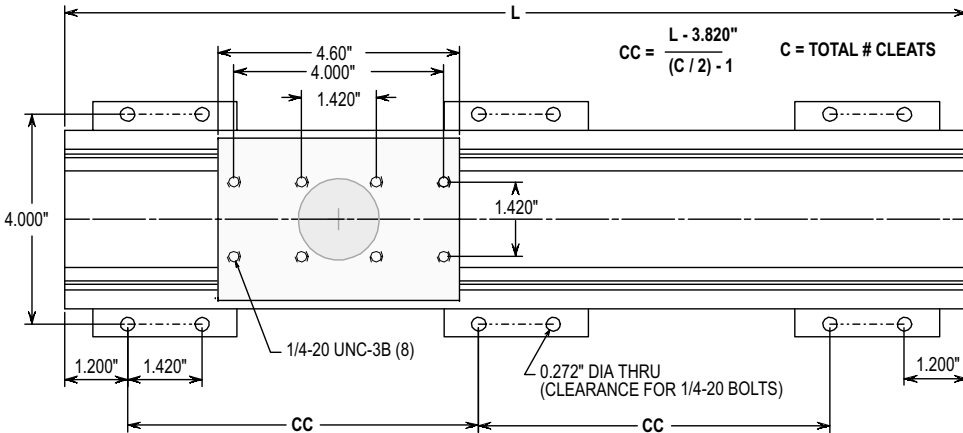

Cleat and T-slot Mounting Methods

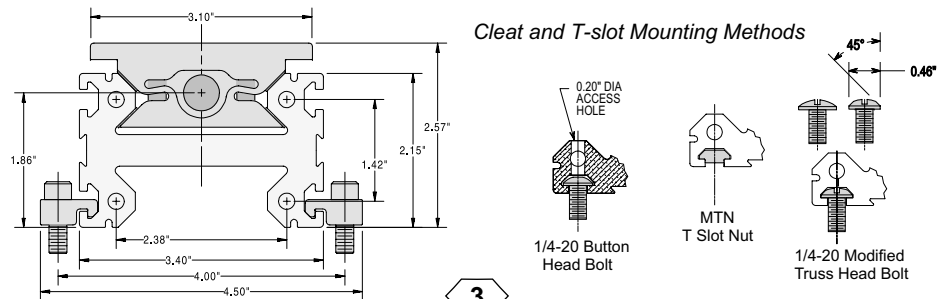

3

## End Plate Mounting

Refer to drawing at right for hole pattern for end mounting. Surface should be steel or aluminum and have 1/4-20 UNC threaded holes with a minimum thread depth of 0.30". Use Velmex MB-1 or equal grade 8 bolts. Start with bolts finger tight and then tighten bolts progressively alternating sides and diagonals. Finish by tightening bolts to 95 in-lbs. *Thread locking compound (Loctite) is recommended for all mounting bolts.*

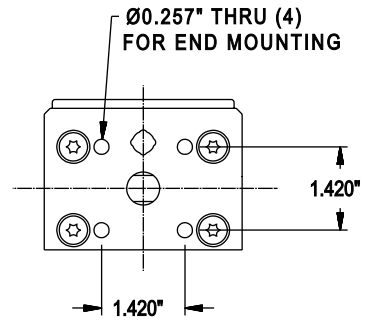

### WARNING

Cantilever load on end plate must not exceed 94 ft-lbs.

## End Plate Removal

It may be necessary to remove the end plate to insert T-slot nuts for limit switches or side mountings. To remove the end plate the carriage should first be positioned all the way to the end plate end. This will insure the end plate centers to the center of the lead screw as determined by the carriage on reinstallation. Use a T-30 Torx wrench to remove the four end plate bolts. When reinstalling the plate torque the bolts to 100 in-lbs.

## XY Mounting

Attach Y axis base to X axis carriage with a pair of MC-2 cleats and four MB-1 bolts. Start with bolts finger tight and then tighten bolts progressively alternating side to side and diagonally. Finish by tightening bolts to 95 in-lbs. *Thread locking compound (Loctite) is recommended for all mounting bolts.*

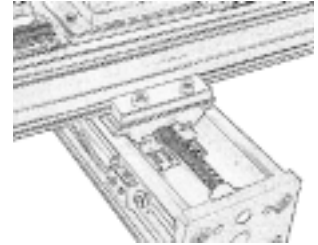

### WARNING

A pair of properly installed cleats have 425 lbs of holding capacity before slipping. However, if the cleats loosen due to vibration or improper tightening the BiSlide stage can slip resulting in damage to external equipment, or serious injury. In critical applications cleats should be drilled and pinned to the BiSlide base.

## XZ Mounting (End Plate To Carriage)

Attach Z axis end plate to X or Y axis carriage with four MB-1 bolts. Start with bolts finger tight and then tighten bolts progressively alternating side to side and diagonally. Finish by tightening bolts to 95 in-lbs.

*Thread locking compound (Loctite) is recommended for all mounting bolts.*

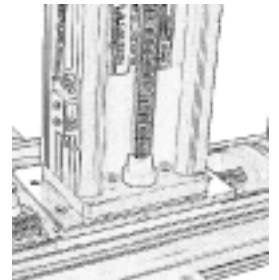

## Load Attachment (Refer to page 2 for maximum load capacity)

Refer to drawing on page 3 for mounting hole pattern in carriage. When mounting to the carriage surface use four Velmex MB-1 (1/4-20 UNC) or equal grade 8 bolts. Bolts must thread into the carriage to a minimum depth of .30" depth. Torque bolts to 95 in-lbs. User attached Blocks, Plates, etc. must be flat. Attaching non-flat surfaces may distort the carriage causing binding.

*Thread locking compound (Loctite) is recommended for all mounting bolts.*

4

## Lubrication

Motor Driven BiSlide Assemblies should be lubricated with Velmex BL-1 oil if minimum friction, maximum life, and repeatability are a concern. Using any other than BL-1 lubricant may damage bearing pads, nut, or lead screw support bearing. Re-lube when the lead screw and ways appear dry of lubricant. Continuous use applications with heavy loads may necessitate daily lubrication.

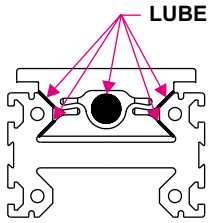

To lubricate BiSlide Assembly, traverse carriage near center of travel and apply 3 to 4 drops of oil to the end of carriage at the way surfaces and on the lead screw threads. Apply oil to both end of carriage, refer to the diagram above for lube points.

Occasionally apply 1 to 2 drops of BL-1 to the point where the lead screw enters the lead screw support bearing (end plate end).

## Adjustments (see page 7 for limit switch adjustment)

The following adjustments may be necessary after break in period and less frequently thereafter.

### StabilNut™

The Lead Screw Nut (StabilNut) has adjustable mesh to minimize backlash. To minimize backlash, tighten (Clockwise with 5/32 hex key) nut tension screws (see diagram at right) equally 1/8 of a turn maximum at a time. Test for over tightness by turning lead screw by hand. Lead screw should rotate by twisting with index fingers and thumbs of both hands.

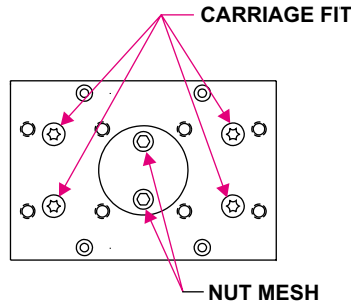

**!** Do not remove nut tension screws. If tension screws are unscrewed more than 2 turns the nut tension plate may dislodge from the nut requiring removal of the carriage to refasten the plate.

## Carriage

Carriage fit is adjustable by tightening the four T-30 Torx head bolts on the carriage surface (see diagram above). Carriage free-play is indicated by a clunking/knocking noise when pulling up and down on the corners of the carriage. To reduce carriage free-play tighten (Clockwise) each bolt equally 1/8 of a turn maximum at a time.

**!** Failure to adjust carriage bolts evenly will result in loss of parallelism or proper way contact. An out of parallel carriage may angle the limit switch actuator cam to be either too high or low resulting in limit switch failure. Over tensioning carriage will result in binding, rapid lead screw, StabilNut, and pad wear.

To check if the carriage is parallel to the base, place a small carpenters or machinists level (right angles to traversing direction) across the carriage, note where the bubble is, now move the level to the top of the BiSlide base, if the bubble is in the same place the carriage is parallel. If the carriage seems to clunk only when pulling and pushing on one diagonal of the carriage, then back off slightly on the adjustment bolts at the other diagonal, and re-tighten all four bolts evenly 1/8 turn maximum. Use a level to measure and maintain parallelism to the base.

## Motor Mounting

Before attaching a motor to a BiSlide assembly, the carriage should be first positioned all the way to the motor end. This will insure the motor centers to the center of the lead screw as determined by the carriage. Install motor and tighten the four 10-32 socket cap screws on the motor flange.

There are four pairs (4 screws on each side, see picture above) of draw screws on the motor coupling. The three pairs closest to the motor need to be tightened evenly, and Torqued to 26 in-lbs. Start with the pair closest to the motor, rotate lead screw 1/2 turn to reach the screw on the opposite side. Repeat sequence until all three pairs are tightened.

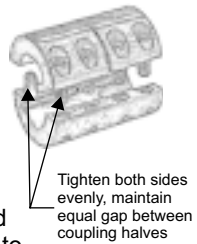

**!** Never loosen the pair of coupling screws closest to the bearing assembly. The bearing assembly has a 50 lb. pre-load that will be lost if the coupling is completely unclamped.

## Motor Wiring (for Velmex installed step motors)

Pin	Motor	Cable (6 wire)	Cable (4 wire)	Slo-Syn	Vexta	Pacific Scientific*
1	BC	W	-	W	W	W/Y & W/R
2	B2	Gn	Gn	Gn	Bu	R
3	AC	Bk	-	Bk	Y	W/Bk & W/O
4	A2	Or	Bk	W/R	Bk	O
5	A1	R	R	R	Gn	Bk
6	B1	Bu	W	W/Gn	R	Y

\* 8 lead motor with wires combined at AC and BC for 6 lead configuration

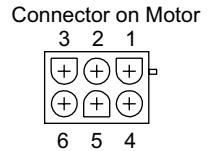
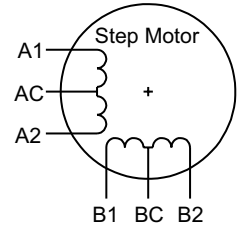

Amp 1-480705-0 (mates with: 1-480704-0)

Step	A1	A2	B1	B2	BC & AC
1	Gnd	N/C	Gnd	N/C	+V
2	N/C	Gnd	Gnd	N/C	
3	N/C	Gnd	N/C	Gnd	
4	Gnd	N/C	N/C	Gnd	
1	Gnd	N/C	Gnd	N/C	

CCW (-)  
↓

↑  
CW (+)

Gnd = Ground level  
N/C = No Connection  
+V = Motor label voltage or, current limited over-drive voltage

Step	A1	A2	B1	B2
1	+	-	-	+
2	-	+	-	+
3	-	+	+	-
4	+	-	+	-
1	+	-	-	+

CCW (-)  
↓

↑  
CW (+)

+ = Positive current flow  
- = Negative current flow

## Limit Switch Wiring

	Pin	Switch	Cable
Inner Switch (Motor End)*	1	C	W
	2	NC	R
Outer Switch (End Plate)	3	NC	Gn
	4	C	Bk

\* Negative direction on Velmex Controllers (carriage moves toward motor end)

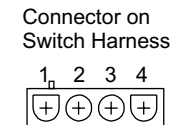

Amp 1-480703-0 (mates with: 1-480702-0)

Switches are wired on the normally closed (NC) terminals. To rewire to normally open (NO), remove switch cover by unscrewing the two small screws on the switch housing, and resolder to the NO terminal.

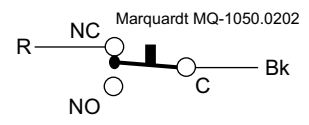

## Coupling Cover Removal and Installation

To gain access to the motor or knob coupling the coupling/bearing cover must be pried off. Use a broom handle or hammer handle as a fulcrum. Place the handle across the top of the BiSlide base near the coupling/bearing cover. Insert a large flat blade screwdriver between the cover gap just above the lead screw, using the handle as a fulcrum, push down on the screwdriver to pry the cover off. To install cover push straight down with finger pressure and work top edges in until cover locks completely into place. Use Velmex BL-1 Lubricant on inside edges of cover to ease installation.

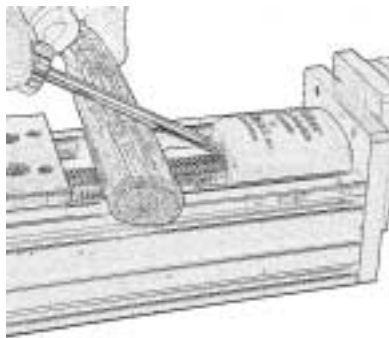

## Converting Manual Model to Motor Driven

Refer to coupling/bearing cover removal procedure to obtain access to the motor/knob coupling. Before removing the knob, the carriage should be first positioned all the way to the knob end. This will insure the motor centers to the center of the lead screw as determined by the carriage. Loosen 1/2 turn the 3 pairs of coupling screws closest to the knob. Rotate lead screw 180 degrees for access to all screws.

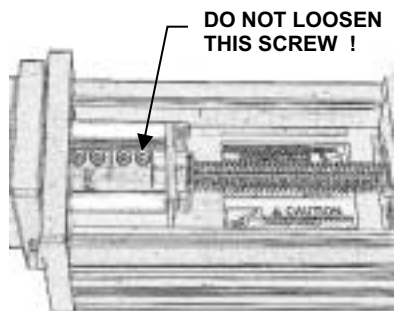

**⚠** Never loosen the pair of coupling screws closest to the bearing assembly. The bearing assembly has a 50 lb. pre-load that will be lost if the coupling is completely unclamped.

Remove the knob/shaft assembly, and the 4 screws in the knob/bearing plate. Parts needed to attach motor:

- **NEMA size 23** (2.3" dia.) motors requires Velmex coupling reducing bushing #IM001-15. Bushing is not required if motor has a .375 dia shaft.
- **NEMA size 34** (3.4" dia) motors require Velmex adapter plate #IM001-20. Size 34 Motors must have a standard .375" dia shaft.

Refer to the Motor Mounting procedure on page 6 for attaching motor. Motors, Limit Switches, Cables, and Motor Controllers are all available from Velmex.

## Limit Switches

Limit switches when used with motor controllers can provide over-travel protection and a precision home reference. BiSlide limit switches are repositionable. To change location of switches, loosen the two phillips head screws on the switch plate and slide to new position and retighten screws.

### ⚠ CAUTION

Failure to secure limit switch hold down screws can cause the switch not to actuate. Also, improper carriage adjustment can cause limit switch cam plate to not actuate the switch. See page 5 for proper carriage fit adjustment procedure.

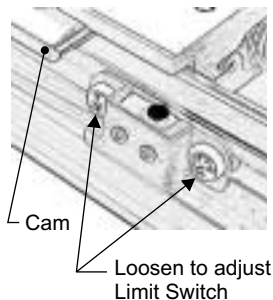

## Warranty

BiSlide Assembly products sold by Velmex are warranted to be free from defects for a period of 5 (five) years on all parts. Velmex's obligation under this warranty does not apply to defects due, directly or indirectly, to misuse, abuse, negligence, accidents, or unauthorized repairs, alterations, or lack of maintenance; or to items that would normally be consumed or require replacement due to normal wear. Claims must be authorized, and a return authorization number issued before a product can be returned.

The warranty does not cover items which are not manufactured or constructed by Velmex, Inc. These components are warranted by their respective manufacturer.

Under the above warranty, Velmex will, at its option, either repair or replace a nonconforming or defective product.

The above warranty is the only warranty authorized by Velmex. Velmex shall in no event be responsible for any loss of business or profits, downtime or delay, labor, repair, or material costs, injury to person or property or any similar or dissimilar incidental or consequential loss or damage incurred by purchaser, even if Velmex has been advised of the possibility of such losses or damages.

Inasmuch as Velmex does not undertake to evaluate the suitability of any Velmex product for any particular application, the purchaser is expected to understand the operational characteristics of the product, as suggested in documentation supplied by Velmex, and to assess the suitability of Velmex products for this application.

## CE Declaration of Conformity

Application of Council Directive 89/392/EEC Annex I Machinery Safety  
Conformity Declared to Standard 89/392/EEC

Manufacturer VELMEX, INC.  
Manufacturer's Address 7550 State Rt. 5 & 20, Bloomfield, NY 14469, USA

Model Name BISLIDE Assemblies

**The undersigned declares that the above named equipment conforms to the above Standard and Directive.**

Signature Mitchel Evans Date August 17, 2000

Name Mitchel Evans

Position Vice President Engineering Company Velmex, Inc.

## Contact Information

By Phone: 716-657-6151 and 800-642-6446

By Fax: 716-657-6153

Email: info@velmex.com

On the Internet: www.velmex.com and www.bislide.com

By mail: Velmex, Inc.  
7550 State Route 5 & 20  
Bloomfield, NY 14469 USA



Copyright 2001 Velmex Inc. All rights reserved. Velmex, the Velmex logo, UniSlide, BiSlide and StabiNut are trademarks of Velmex Inc. All other trademarks are the property of their respective owners.