



HEIDENHAIN



Product Information

LIDA 200 Series Exposed Linear Encoder

March 2006

LIDA 200 Series

Incremental linear encoder with very large mounting tolerances

- For measuring steps up to 0.5 μm
- Tape from the roll
- Attachment of the scale tape on adherable scale-tape carrier (LIDA 2x7) or by adhesion directly to mounting surface (LIDA 2x9)
- Equidistant reference marks

LIDA 279/289

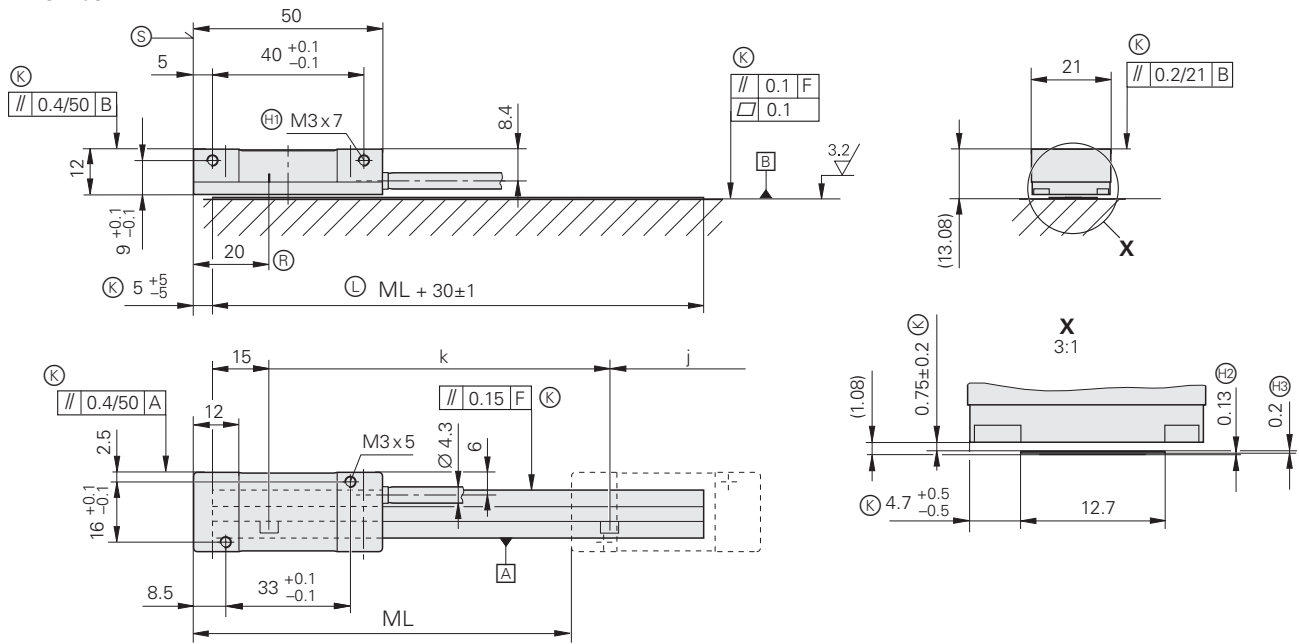

LIDA 277/287

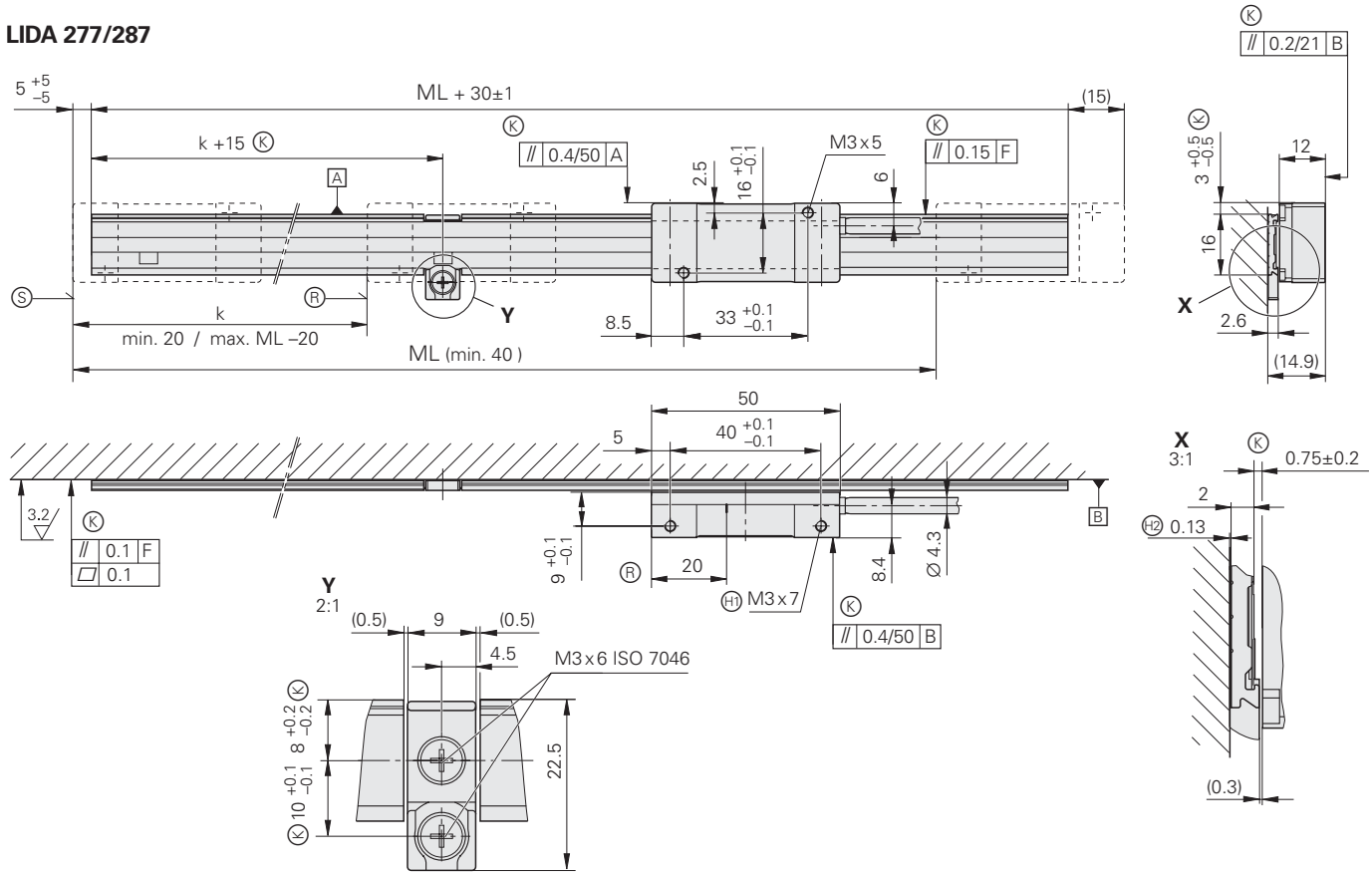

Dimensions in mm



Tolerancing ISO 8015
ISO 2768 - m H
< 6 mm: ±0.2 mm

- F = Machine guideway
- Ⓚ = Required mating dimensions
- Ⓜ = Thread at both ends
- Ⓡ = Reference mark
- Ⓛ = Length of scale-tape

- Ⓢ = Beginning of measuring length (ML)
- Ⓧ = Adhesive tape
- Ⓩ = Steel scale tape

Reference mark:

- k = Position of 1st reference mark from the beginning of the measuring length, depending on the cut
- j = Further reference marks located every 100 mm







Specifications	LIDA 287 LIDA 289	LIDA 277 LIDA 279		
Measuring standard Thermal expansion coefficient	Steel scale tape $\alpha_{\text{therm}} \approx 10 \text{ ppm/K}$			
Accuracy grade	$\pm 30 \mu\text{m}$			
Tape from the roll*	3 m, 5 m, 10 m			
Reference marks	Selectable every 100 mm,			
Incremental signals	$\sim 1 V_{\text{PP}}$	\square TTL x10	\square TTL x 50	\square TTL x 100
Grating period	200 μm	200 μm	200 μm	200 μm
Integral interpolation*	–	10-fold	50-fold	100-fold
Signal period	200 μm	20 μm	4 μm	2 μm
Measuring step ¹⁾	–	5 μm	1 μm	0.5 μm
Cutoff frequency	$\geq 50 \text{ kHz}$	–	–	–
Scanning frequency	–	$\leq 50 \text{ kHz}$	$\leq 25 \text{ kHz}$	$\leq 12.5 \text{ kHz}$
Edge separation <i>a</i>	–	$\geq 0.465 \mu\text{s}$	$\geq 0.175 \mu\text{s}$	$\geq 0.175 \mu\text{s}$
Max. traversing speed	$\leq 10 \text{ m/s}$		$\leq 5 \text{ m/s}$	$\leq 2.5 \text{ m/s}$
Vibration 55 to 2000 Hz Shock 11 ms	$\leq 200 \text{ m/s}^2$ (IEC 60 068-2-6) $\leq 500 \text{ m/s}^2$ (IEC 60 068-2-27)			
Operating temperature	0 to 50 °C			
Weight	Scanning head	20 g (without cable)		
	Scale	20 g/m		
	Carrier	70 g/m (only LIDA 2x7)		
	Connector	32 g		
	Cable	30 g/m		
Power supply	5 V $\pm 5 \%$ / < 200 mA (with no load)			
Electrical connection Cable length	Cable 3 m with D-sub connector (15-pin) $\leq 30 \text{ m}$			

* Please select when ordering

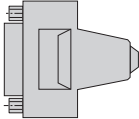
¹⁾ After 4-fold evaluation in subsequent electronics





Electrical Connection

Mating element on connecting cable to encoder connector		D-sub connector (female), 15-pin
		
For connecting cable	Ø 8 mm Ø 6 mm	315650-14

Connecting cable Ø 8 mm [4(2 x 0.14 mm ²) + (4 x 0.5 mm ²) + 2 x (2 x 0.14 mm ²)] Shield on housing		
Connecting cable Ø 6 mm [6(2 x AWG28) + (4 x 0.14 mm ²)]	Ø 8 mm	Ø 6 mm ¹⁾
Complete with D-sub connector (female) and connector (male)	354379-xx	355397-xx
		
With one connector , D-sub (female)	354411-xx	355398-xx
		
Cable without connectors	354341-01	355241-01
		

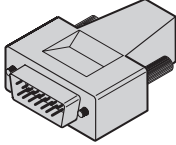
¹⁾ Cable length for Ø 6 mm max. 9 m

Pin Layout

15-pin D-sub connector													
													
													
	Power supply		Incremental signals						Other signals				
	4	2	1	9	3	11	14	7	13	6/8	10	12	15
TTL	U_P	0V	U_{a1}	U_{a1}	U_{a2}	U_{a2}	U_{a0}	U_{a0}	U_{as}	Vacant	Vacant	Vacant	Vacant
1V_{SS}			A+	A-	B+	B-	R+	R-	Vacant				
	Brown/ Green	White/ Green	Brown	Green	Gray	Pink	Red	Black	Violet	/	White	Blue	Yellow

Shield is on housing; **U_P** = Power supply

HEIDENHAIN

DR. JOHANNES HEIDENHAIN GmbH

Dr.-Johannes-Heidenhain-Straße 5

83301 Traunreut, Germany

☎ +49 (8669) 31-0

FAX +49 (8669) 5061

E-Mail: info@heidenhain.de

www.heidenhain.de

For more information

- Brochure: *Exposed Linear Encoders*

