

SCHNEEBERGER
LINEAR TECHNOLOGY

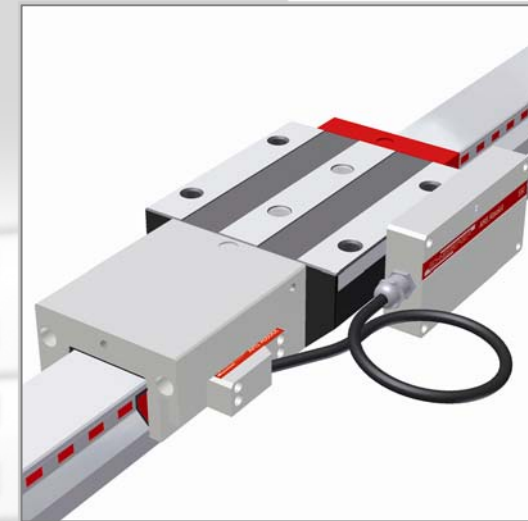

AMSABS 3A

„AMS absolute“

MONORAIL AMSABS 3A

The product **AMSABS 3A for roller guideways** now combines proven magneto-resistive measuring technology with an absolute digital interface. With the proven advantages of AMS products like

- Safe magneto-resistive sensing
- One-piece lengths up to 6 m
- One reading head for all sizes
- Complete interchangeability of rails and reading heads

we have added the following additional features to simplify the operation of distance measuring systems in industrial environments.

- An absolute digital interface
- Display of operating conditions
- Configuration and diagnosis options via a serial link
- Increased operational reliability attained by processing valid information

Structure of the measuring system

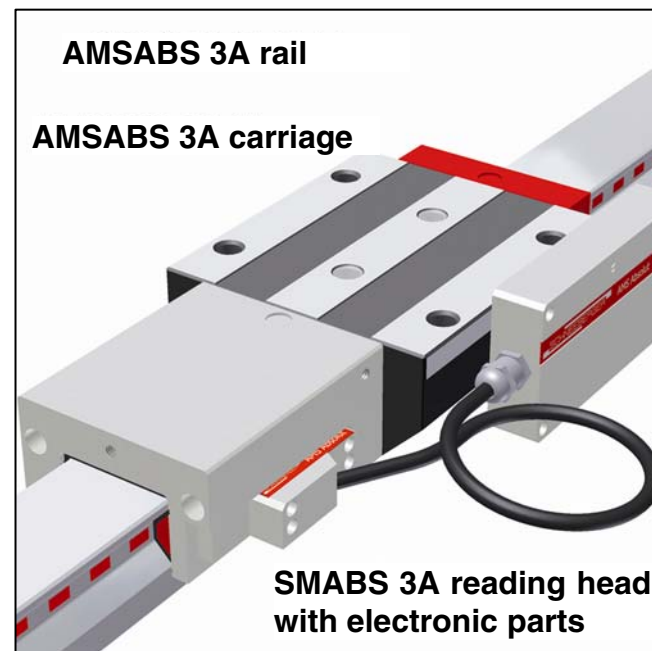

The measuring scale integrated into the rail incorporates both an incremental track and a code track. The measuring scale is protected against damage and disturbance by a hardened cover strip, which is welded to the rail.

The reading head is mounted in an attachment housing and protected by longitudinal and transverse seals. The information from the two tracks is continuously recorded by the contact sensor and the absolute position is calculated by the measuring electronics.

MONORAIL AMSABS 3A operating modes

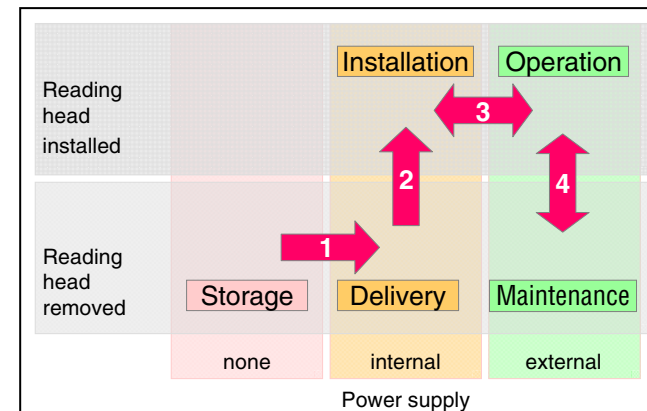

The AMSABS 3A operating modes cover the complete product life cycle. Because the measuring scale only provides an absolute position after the carriage has traveled a short distance to generate valid information; in the installed state and with no external power supply, the signals must be tracked and calculated internally. For this purpose, a magneto-resistive "Low-Power Technology" has been developed.

When they are in storage, the products are in a deactivated state. When they are unpacked (1), the product is activated.

The action of mechanical installation in the AMS attachment housing (2) ensures that the absolute position is correctly sensed. Movements made in this state are recorded with the accuracy of the signal period.

As soon as you switch on the external power supply (3), the absolute position using the precise, interpolated value becomes available. In emergency-stop situations, and when the machine is out of service for longer periods (4), all motions are sensed and saved in memory.

For maintenance work when the machine is in service and during which the reading head must be removed while the power supply is switched on, the absolute position is re-determined when the reading head is installed - it is available immediately the head is screwed in place.

The cumulative duration of operation without the external power supply is 5 years.

Diagnosis and configuration

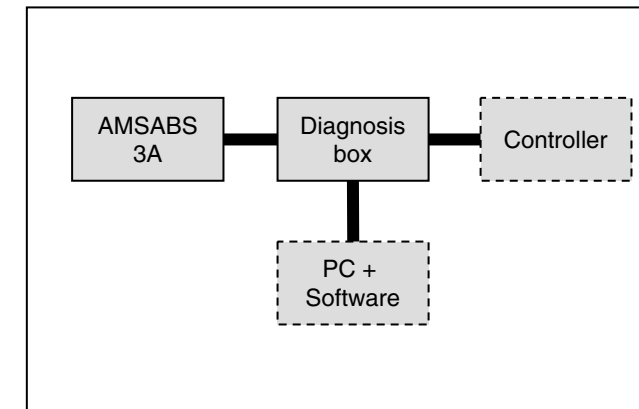

Numerous diagnosis options are available for product AMSABS 3A at slow running speeds.

To exploit them, the communication box must be switched into the cable run.

In diagnosis mode, the following are displayed:

- High resolution analogue signals
- Signal amplitude against time
- Digital position information
- Configured interface parameters
- Current error status

The interface parameters of the SSI interface can be changed in the diagnosis program.

LED operating status indicator

The operating status of the system is displayed by the AMSABS 3A intermediate electronics. This is a simple way to communicate available information to the user.

LED Status	Meaning
Green, continuous	Fault-free operation
Green + red flashes	Internal back-up voltage too low
Green + red flickering	Not referenced (when dismantling)
Red blinking	Supply voltage out of tolerance
Red flickering	Amplitude monitoring has detected out-of-tolerance signals (no function)
Red continuous	Hardware fault (no function)

SSI Interface

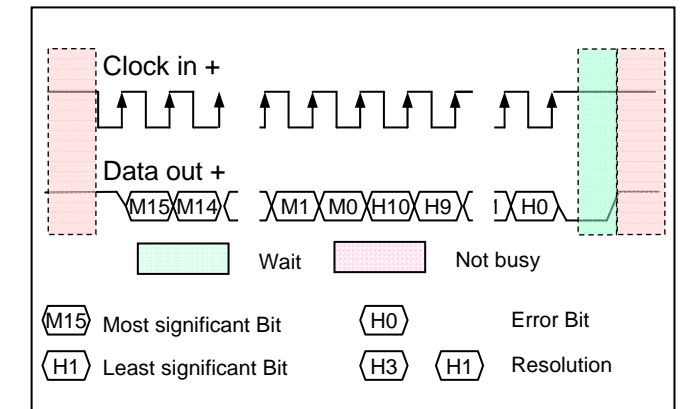

Absolute information is transmitted through a serial clock-synchronised interface.

All information items contain the complete absolute information presented in binary or Gray code. When configured for maximum resolution, the system can transmit 0.1 µm steps.

Every transmitted position value is accompanied by a configurable parity bit and an error bit.

In this way, errors can be detected and the system can operate safely and reliably.

This product can be connected to commercially-available control systems with an SSI interface.

The measuring system can operate with either a 24 V or 5 V supply and should be connected to **only one** of these supply voltages.

Pin layout

Pin	Signal	Signal type
1	-CLK	-Clock
2	+24 V	Supply voltage
3	RxD	RS232 communic.
4	TxD	RS232 communic.
5	+DATA	+Data
6	-DATA	-Data
7	-	NC
8	+CLK	+Clock
9	-	NC
10	0 V GND	Supply voltage
11	-	NC
12	+5 V	Supply voltage

Product overview of rails

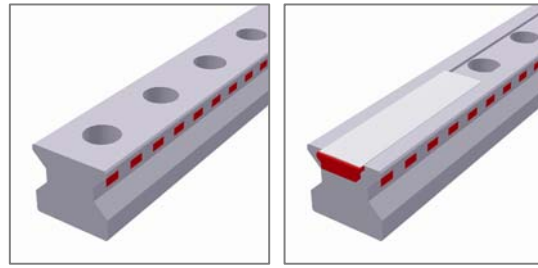

Rail sizes / Rail types	N standard	C for cover strip
25	AMSABS 3A S 25-N	AMSABS 3A S 25-C
35	AMSABS 3A S 35-N	AMSABS 3A S 35-C
45	AMSABS 3A S 45-N	AMSABS 3A S 45-C
55	AMSABS 3A S 55-N	AMSABS 3A S 55-C
65	AMSABS 3A S 65-N	AMSABS 3A S 65-C

Features

screwable vom above	●	●
minimal assembly effort		●
great system length	●	●

Available options for rails

Accuracy

G0	highly accurate
G1	very accurate
G2	accurate
G3	standard

Straightness

KC	standard
----	----------

Coating

CN	none
CH	hard chrome

Locating sides

R11	Reference at bottom, scale at bottom
R12	Reference at bottom, scale on top
R21	Reference on top, scale at bottom
R22	Reference on top, scale on top

Accessories from the standard program

Accessories from the standard program:

- Additional wipers ZCN, ZCV
- Metal wipers ASM
- Steel plugs, brass plugs, plastic plugs

Product overview of carriages

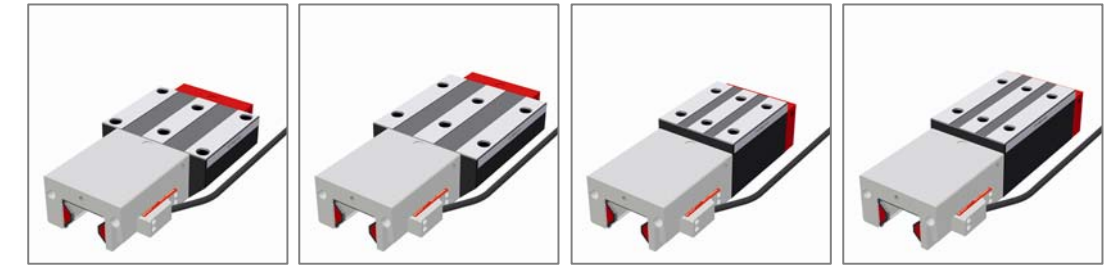

Carriage sizes / Carriage types	A standard	B standard., long	C compact, high	D compact, high, long
25	AMSABS 3A W 25-A	AMSABS 3A W 25-B	AMSABS 3A W 25-C	AMSABS 3A W 25-D
35	AMSABS 3A W 35-A	AMSABS 3A W 35-B	AMSABS 3A W 35-C	AMSABS 3A W 35-D
45	AMSABS 3A W 45-A	AMSABS 3A W 45-B	AMSABS 3A W 45-C	AMSABS 3A W 45-D
55	AMSABS 3A W 55-A	AMSABS 3A W 55-B	AMSABS 3A W 55-C	AMSABS 3A W 55-D
65		AMSABS 3A W 65-B		AMSABS 3A W 65-D

Features

fixing from above	●	●	●	●
fixing from below	●	●		
for medium loads	●		●	
for high loads		●		●

Available options for carriages

Accuracy

G0	highly accurate
G1	very accurate
G2	accurate
G3	standard

Preload

V1	low
V2	medium
V3	high

Reference side

R1	Reference at bottom
R2	Reference on top

Coating

CN	none
CH	hard chrome

Lube connections

S10	left center
S20	right center
S11	top left
S21	top right
S12	lower left side
S22	lower right side

S13	upper left side
S23	upper right side
S32	left side
S42	right side

Lubrication as delivered

LN	Oil protect
LG	Grease protect
LV	Full greasing

Interface

TMA	TMA-SSI 0,3 m
TSA	TSA-SSI 3 m

Reading head position

P1	right top
P3	left bottom

Order code AMSABS 3A rails

Quantity	1x	AMSABS 3A S	35	-C	-G1	-KC	-R11	-2936	-28	-28	-CN
Rail											
Size											
Type											
Accuracy											
Straightness											
Reference sides											
Rail length L3											
Position of first fixing hole L5											
Position of last fixing hole L10											
Coating											

Order code AMSABS 3A measuring carriages

Quantity	1x	AMSABS 3A W	35	-B	-P1	-G1	-V3	-R2	-CN	-S12	-LN	-TSU
Measuring carriage												
Size												
Type												
Reading head position												
Accuracy												
Preload												
Reference side												
Coating												
Lube connection												
Lubrication as delivered condition												
Interface												

Technical data of rails

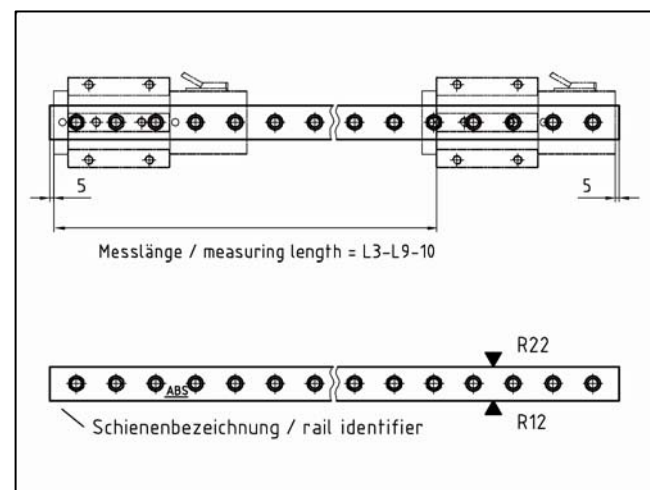

Dimensions of reading head

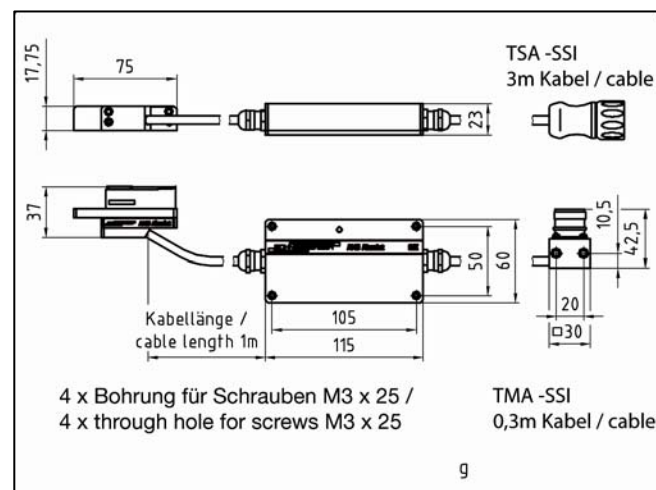

Technical data of carriages

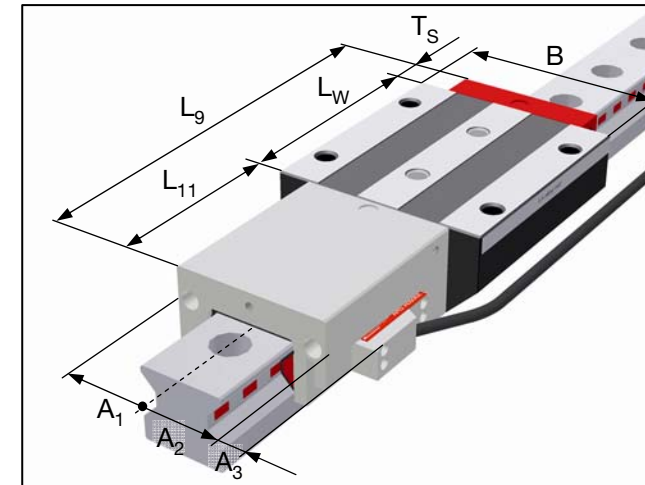

Size	B				L _w			
	-A	-B	-C	-D	-A	-B	-C	-D
25	70	70	48	48	57	79,4	57	79,4
35	100	100	70	70	76	103	76	103
45	120	120	86	86	100	135	100	135
55	140	140	100	100	120	162	120	162
65	-	170	-	126	-	201	-	201

Size	L ₉				T _s	L ₁₁	A ₁	A ₂	A ₃
	-A	-B	-C	-D					
25	164	187	164	187	12	95,2	31	31	14,5
35	192	219	192	219	16,5	99,7	34	34	14,5
45	221	256	221	256	18,8	101,9	42	42	10,5
55	247	289	247	289	21,8	104,9	49	49	6,5
65	-	335	-	335	25	109	61,5	61,5	0

For basic data and further information about this product please refer to our main catalog MONORAIL.

Technical data

System properties

Magnetic scale	Hard magnetic graduation High-resolution incremental track Absolute coded reference track
Signal period	200 µm
Maximum length	6000 mm

Accuracy

Accuracy class	± 5 µm / 1000 mm ± 2 µm / 40 mm
Periodic deviation	± 0,7 µm typically
Hysteresis	< 0,5 µm

Movement

Maximum speed	3 m/s
Maximum acceleration	30 g

Environment

Protection class	IP 67
Working temperature	0° - +70° C
Storage temperature	-20° - +70° C
Vibration / impacts	30 g
Compatibility	RoHS

Power supply

Supply voltage	5 V ± 10% or 24 V ± 10%
Current consumption	< 200 mA no load on outputs
Back-up battery	Lithium-thionyl-chloride V = 3,4 ... 3,6 V size AA

SSI interface

Measuring cycle	25 µs (latency < 10 µs)
Signal coding	Binary code 27 Bit 0,0976 µm = LSB
Max. clock frequency	1 MHz
Electrical interface	RS 422