

SCHNEEBERGER
LINEAR TECHNOLOGY

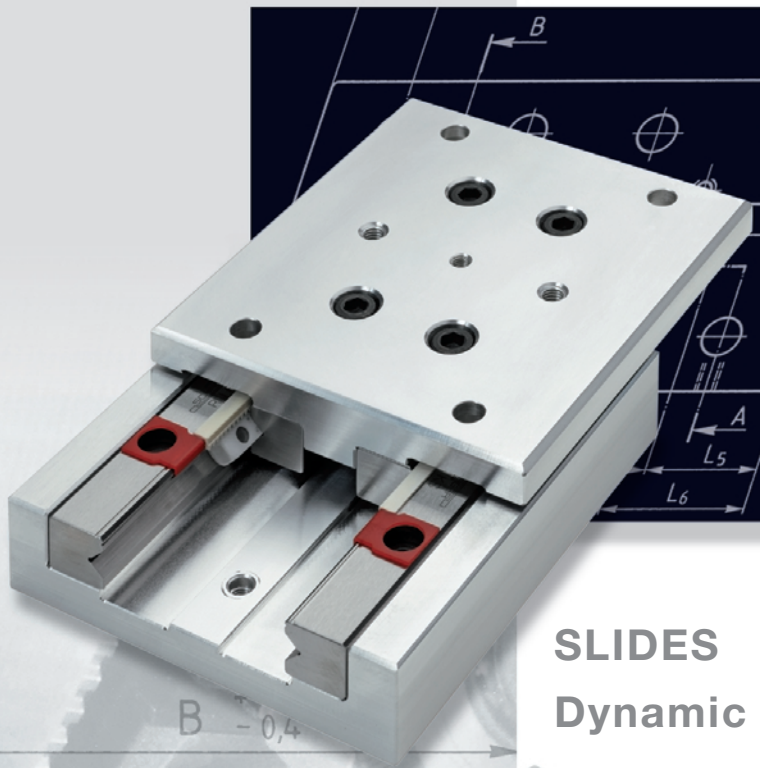

SLIDES
Dynamic and Precise

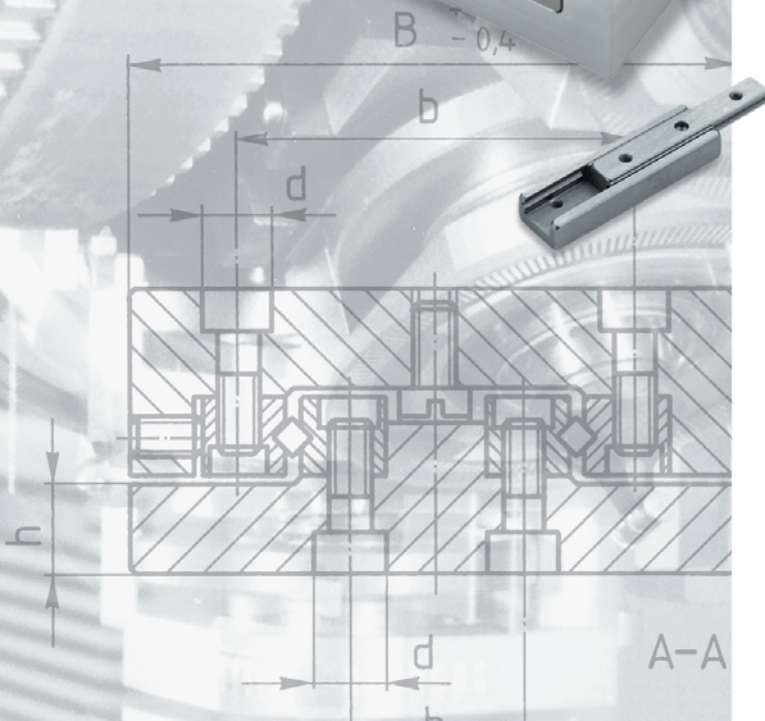

Table of Contents

1 Product Overview	S ● 4
2 Applications	
2.1 Die Attach System with ND 1	S ● 6
2.2 Multimode Fusion Splicer with NK 1 Tables	S ● 7
2.3 Printed Circuit Board Assembly with NDN 1	S ● 8
2.4 Laser Measuring Device with ND 1	S ● 9
3 Frictionless Tables Type NK	
3.1 Frictionless Tables Type NK	S ● 11
3.2 Material	S ● 11
3.3 Standard Model	S ● 11
3.4 Special Models	S ● 11
3.5 Specifications	S ● 12
3.6 Accessories	S ● 16
4 Frictionless Tables Type NKL	
4.1 Frictionless Tables Type NKL	S ● 17
4.2 Material	S ● 17
4.3 Standard Model	S ● 17
4.4 Special Model	S ● 17
4.5 Specifications	S ● 18
5 Micro Frictionless Tables Type ND	
5.1 Micro Frictionless Tables Type ND	S ● 23
5.2 Material	S ● 23
5.3 Standard Model	S ● 23
5.4 Special Model	S ● 23
5.5 Specifications	S ● 24
6 Micro Frictionless Tables Type NDN	
6.1 Micro Frictionless Tables Type NDN	S ● 27
6.2 Material	S ● 27
6.3 Standard Model	S ● 27
6.4 Specifications	S ● 28
7 Technical Information	
7.1 Acceptance Tolerances	S ● 30
7.2 Accuracy	S ● 30
7.3 Materials	S ● 32
7.4 Permissible Operating Temperatures	S ● 32
7.5 Lubrication	S ● 32
7.6 Permissible Velocities and Accelerations	S ● 32
7.7 Friction, Running Accuracy and Smoothness	S ● 32
8 Design and Fitting Guidelines	
8.1 Horizontal and Vertical Fitting	S ● 33
8.2 Attaching Frictionless Tables	S ● 33
8.3 Preloading Frictionless Tables	S ● 33
8.4 Design of Base Unit	S ● 33
8.5 Accessories for Frictionless Tables	S ● 33
9 Dimensioning Frictionless Tables	
9.1 Load Carrying Capacity and Operational Life	S ● 34
9.2 Moment Loading	S ● 35

Frictionless Tables Type NK

- Single axis model in steel or cast-iron depending on the size
- With roller cages
- 5 sizes
- Lengths from 25 to 510 mm
- Strokes from 10 to 450 mm
- Supports a variety of applications due to the many different sizes
- For highest accuracy requirements
- For highest accelerations available with FORMULA-S



Frictionless Tables Type NKL

- Single axis model
- Light design, table components in aluminum
- 4 sizes
- With roller cages
- Lengths from 25 to 410 mm
- Strokes from 10 to 280 mm
- For highest accelerations available with FORMULA-S



Micro Frictionless Tables Type ND

- Single axis model in steel
- 3 sizes
- With roller cages
- Lengths from 25 to 155 mm
- Strokes from 12 to 90 mm
- Low friction force
- For highest accuracy requirements



Micro Frictionless Tables Type NDN

- Single axis model in corrosion resistant steel
- 3 sizes
- With ball cage in brass
- Cage centering mechanism which helps to avoid cage creep
- Length from 10 to 80 mm
- Strokes from 5 to 70 mm
- For highest accuracy requirements
- Suitable for high speed applications



2.1 Die Attach System with ND 1

One of the ideal applications for the ND 1 table is in Die Attach equipment. Die Attach is one of the central steps in the manufacture of integrated circuits (IC's). In the first step, a wafer full of IC's is sliced up with a diamond dicing saw. After sawing, the individual IC's or «die» are picked off of the sawed wafer and placed onto a metal lead frame in the die attach operation. The lead frame has been prepared with an epoxy adhesive, which secures the die to the leadframe. In subsequent operations the metal pads on the die are connected to the metal leads of the frame providing an electrical connection to the printed circuit board to which the completed IC will eventually be attached. The high speed Z-axis of the die attach machine carries out the actual «pick and place» operation. The individual die are picked from a wafer and placed on the lead frame in a specific location. A machine vision system is used to accurately locate the independent positions, of both the die on the wafer and the leadframe where it will be placed. The accuracy of the joining of the two components is critical to the success of subsequent operations.

Product	ND 1
Stroke	25 mm
Nominal stroke	15 mm
Operating orientation	vertical
Position accuracy	± 0.05 mm
Acceleration	30 m/s ²
Straightness and Flatness of travel	0.004 mm

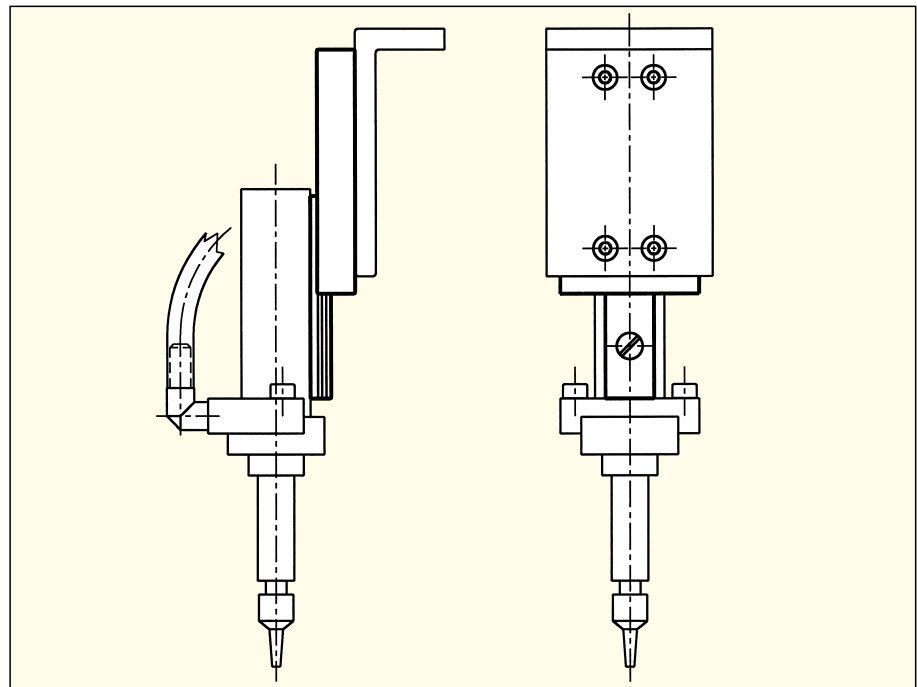

2.2 Multimode Fusion Splicer with NK 1 Tables

Multimode Fusion Splicers are portable optical fibre joining machines weighing approximately 10 kg. These are used in the field for the installation of optical fibre systems, for example for LAN's (Local Area Networks). Using a high precision process, two optical fibres are fusion joined together. Great accuracy is required so that the transmission quality of the optical fibre is not significantly reduced. Two clamping devices, one for each fibre, accurately locate and hold the two optical fibres and are guided by SCHNEEBERGER NK 1 roller tables. Prior to splicing, the fibre ends are precisely aligned to each other to sub-micron accuracy in three mutually orthogonal axes. This adjustment is effected using SCHNEEBERGER NK 1 tables driven by stepper motors. The accuracy of adjustment is monitored on a built-in LCD screen via an integral CCD camera system and controlled manually by means of a simple handwheel. Thereupon the fusion process takes place to produce a high quality, low-loss joint. This whole process takes on average one minute. Finally, the completed splice is protected by a heat shrink sleeve which is applied using the fusion splicer's integral heatoven.

Product	NK 1
Stroke	12 mm
Nominal stroke	10 mm
Operating orientation	vertical/horizontal
Position accuracy	0.001 mm
Acceleration	low
Straightness and Flatness of travel	0.002 mm

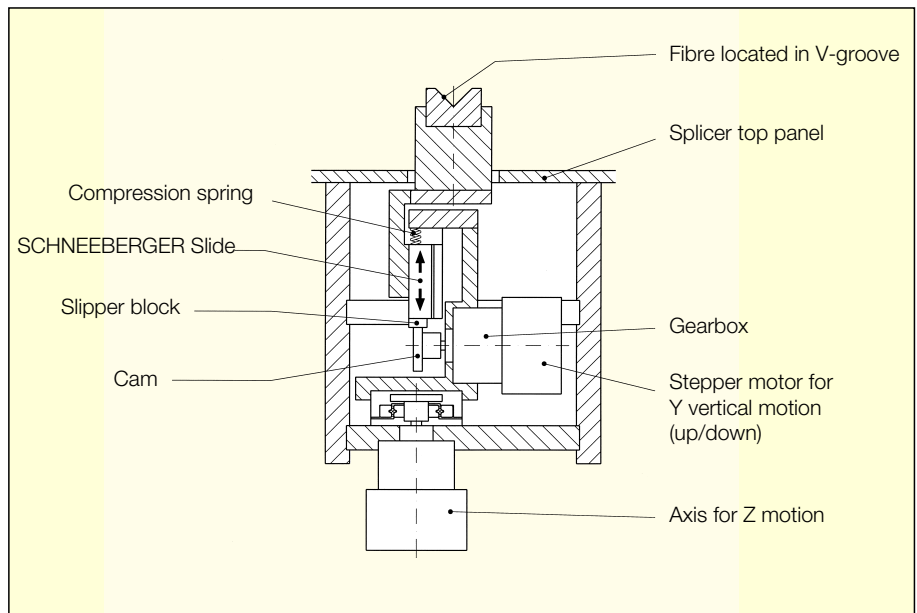

2.3 Printed Circuit Board Assembly with NDN 1

In this application, NDN 1 micro frictionless tables are utilized for placing electronic components such as resistors, capacitors, coils and integrated circuits on printed circuit boards. With a gripper installed on the top of the SCHNEEBERGER NDN 1 micro frictionless table, the components are picked from a large hopper. The parts are then placed on a specific position on the printed circuit board with a Z-stroke of the table. In this case, the NDN 1 table is driven by a synchronous toothed belt. The SCHNEEBERGER NDN 1 distinguishes itself particularly by its constant precision under the extra demands on service life and accuracy imposed by the high dynamic loading found in this application.

Product	NDN 1
Stroke	20 mm
Nominal stroke	15 mm
Operating orientation	vertical
Position accuracy	0.03 mm
Acceleration	up to 15 m/s ²
Straightness and Flatness of travel	0.003 mm

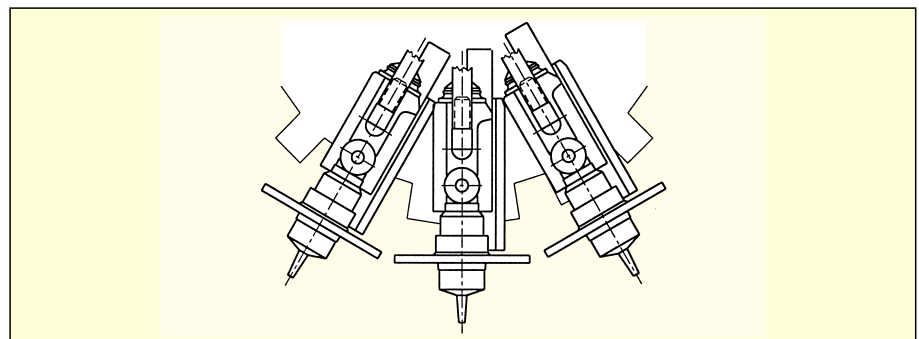
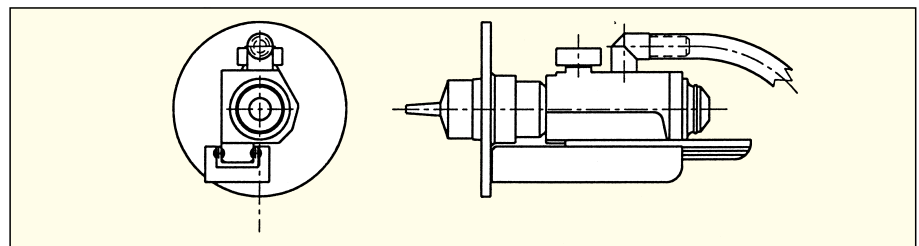

2.4 Laser Measuring Device with ND 1

In section 2.2 Multimode Fusion Splicer, the connecting of glass fibres in the field was described. This application involves the measurement of glass fibre connections. The measuring procedure is based on the angle change of a reflector, in which the wave length of the laser beam is changed and evaluated. The mechanical rotation of the reflector is controlled through a stepping motor drive with a micrometer spindle. The stepping motor is installed on a roller table ND 1, in order to compensate for the longitudinal movement of the micrometer screw. This makes exceptionally high demands on the running characteristics of the roller table, since this has a direct influence on the measurement results.

Product	ND 1
Stroke	32 mm
Nominal stroke	25 mm
Operating orientation	horizontal
Position accuracy	no special requirements
Acceleration	low
Straightness and Flatness of travel	0.004 mm

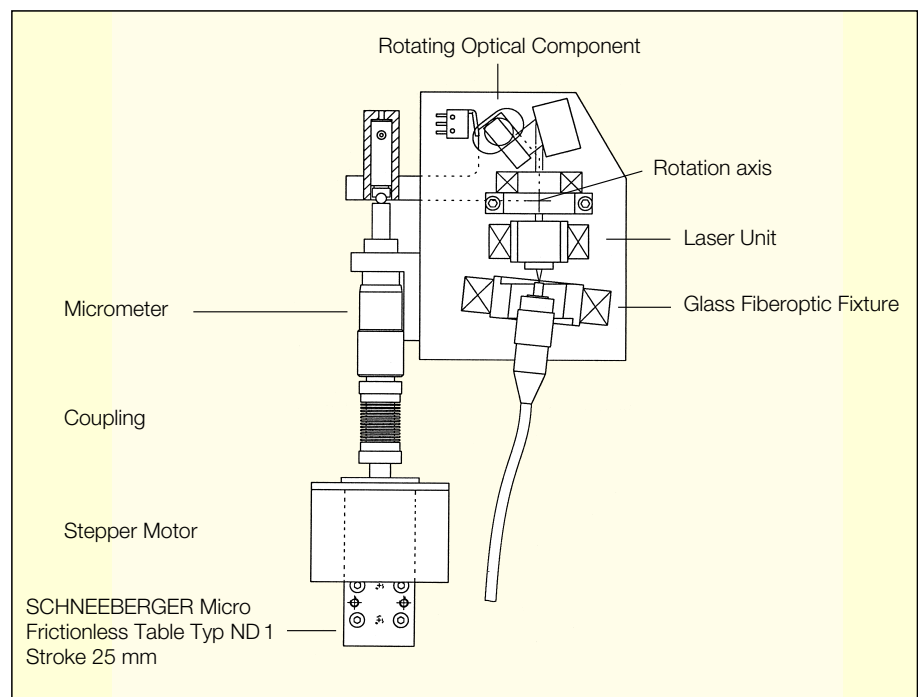

3.1 Frictionless Tables Type NK

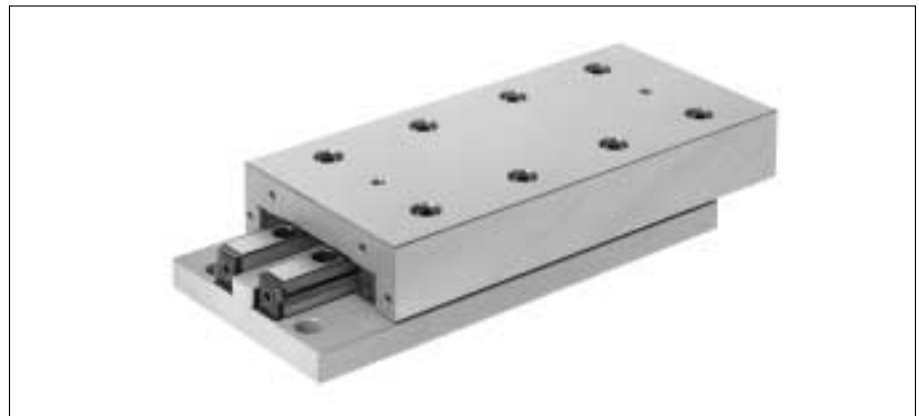

- Single axis model in steel or cast-iron depending on the size
- With roller cages
- 5 sizes
- Lengths from 25 to 510 mm
- Strokes from 10 to 450 mm
- Supports a variety of applications due to the many different sizes
- For highest accuracy requirements
- For highest accelerations available with FORMULA-S

3.2 Material

Sizes NK 1 and 2 = Steel
 Sizes NK 3, 6 and 9 = Cast-iron

3.3 Standard Model

Type NK frictionless tables consist of equal length upper and lower sections and type R linear bearings. All tables are equipped with type AC roller cages and type GB endpieces and can be mounted vertically or horizontally. The lower section includes standardized attaching holes. The sides opposite to the setscrews in the upper and lower sections can be used for mounting purposes. For the standard model stroke limiting is made by means of two screws in the upper section and one screw in the lower section. These screws can withstand only small forces or impacts in the direction of motion and should not be used as stops. With FORMULA-S these screws are no more necessary due to the cage assist system.

3.4 Special Models

Standard Attaching Holes (-B)

In the upper section (other hole configurations on request)

Roller Cages Type EE (-EE)

Plastic material, only available for sizes 6 and 9. Provides sealing against dirt and dust; therefore somewhat stiffer motion

Ball Cages Type AK (-AK)

For reduced sensitivity to dirt. Lower load carrying capacity

Cage assist integrated (-KS)

for high dynamics and all assembly orientations for sizes 3 and 6

3.5 Specifications

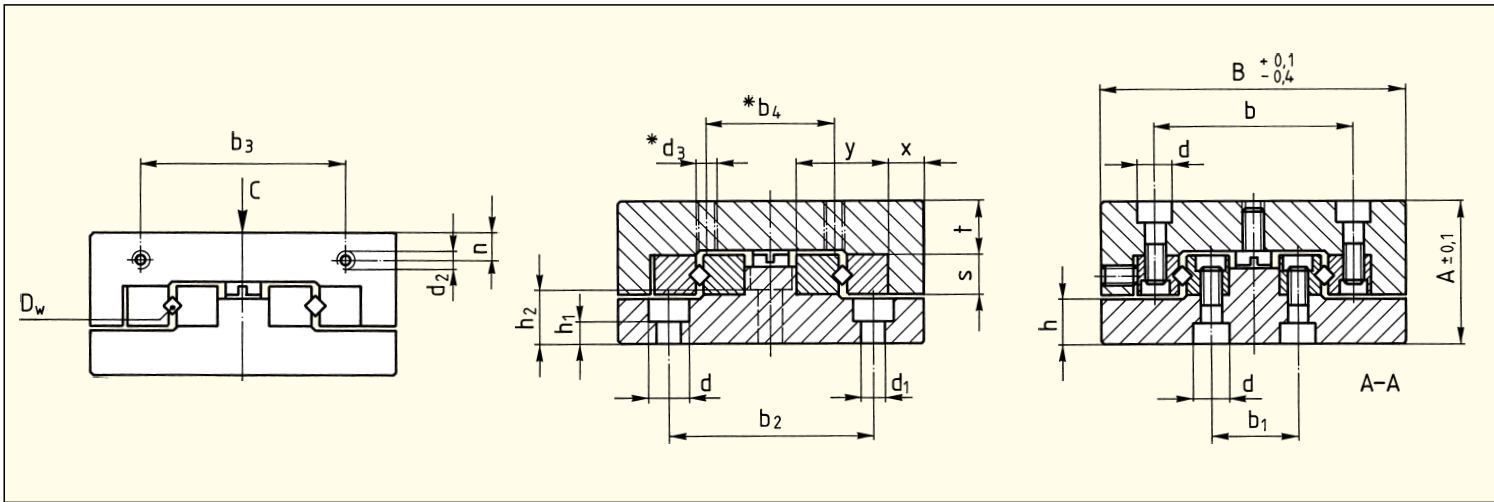

Order No.	Dimensions (mm)				L	L ₁	L ₂	*L ₃	L ₄	L ₅	*L ₆	L ₇	b	b ₁	b ₂	b ₃	*b ₄	d	d ₁	
	A	B	D _w	H																
NK 1-25				10	25	1×10	–			3.0										
NK 1-35				18	35	2×10	1×10			4.5										
NK 1-45				25	45	3×10	2×10			6										
NK 1-55	17	30	1.5	32	55	4×10	10	3×10	7.5	7.5	12.5	3.5	18.4	8.6	22	12	10	4.1	2.55	
NK 1-65				40	65	5×10		4×10		8.5										
NK 1-75				45	75	6×10		5×10		11										
NK 1-85				50	85	7×10		6×10		13.5										
NK 2-35				18	35	1×15	–			3										
NK 2-50				30	50	2×15	1×15			4.5										
NK 2-65				40	65	3×15	2×15			7										
NK 2-80	21	40	2	50	80	4×15	15	3×15	10	9.5	17.5	5	25	11	30	16	15	6	3.5	
NK 2-95				60	95	5×15		4×15		12										
NK 2-110				70	110	6×15		5×15		14.5										
NK 2-125				80	125	7×15		6×15		17										
NK 3-55				30	55	1×25	–			5.5										
NK 3-80				45	80	2×25	1×25			10.5										
NK 3-105				60	105	3×25	2×25			15.5										
NK 3-130	28	60	3	75	130	4×25	25	3×25	15	20.5	27.5	10	39	17	40	40	25	7.5	4.5	
NK 3-155				90	155	5×25		4×25		25.5										
NK 3-180				105	180	6×25		5×25		30.5										
NK 3-205				130	205	7×25		6×25		30.5										

* Only with special model B

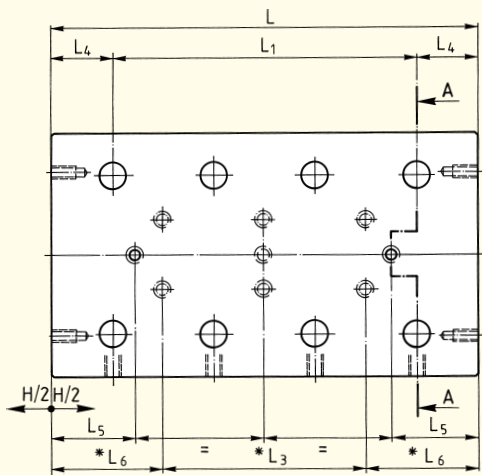

Layout of the standard attaching holes in the lower section

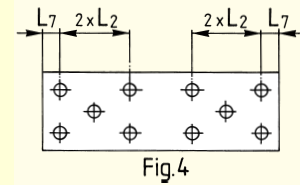
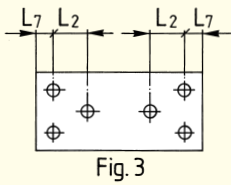
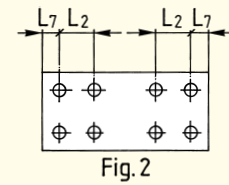
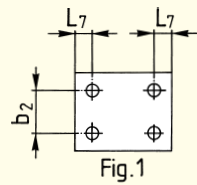

d_2	$*d_3$	h	h_1	h_2	n	s	t	x	y	C in N	M_L in Nm	M_Q in Nm	Weight in kg	Fig.
M2	M2	5.5	3	-	2.5	4	7	4	8.5	250	1.20	1.69	0.08	1
										350	1.80	2.36	0.112	1
										450	2.40	3.04	0.144	1
										550	3.00	3.71	0.176	2
										650	3.60	4.39	0.208	2
										750	4.20	5.06	0.24	2
M2	M3	6.5	3	-	3.4	6	8	5	12	900	5.10	6.08	0.277	2
										425	2.72	3.83	0.18	1
										595	4.08	5.36	0.26	1
										850	6.12	7.65	0.34	1
										1020	7.48	9.18	0.42	2
										1275	9.52	11.48	0.5	2
										1445	10.88	13.01	0.58	2
1700	12.92	15.30	0.68	2										
M3	M4	9	4.5	10	5.5	8	10.5	7	18	910	7.80	12.74	0.57	1
										1300	11.70	18.20	0.8	1
										1820	16.90	25.48	1.03	1
										2210	20.80	30.94	1.26	1
										2730	26.00	38.22	1.49	3
										3120	29.90	43.68	1.72	3
										3510	33.80	49.14	1.95	4

Ordering example: 1 Frictionless table NK 3-105 or 1 Frictionless table NK 3-105-B

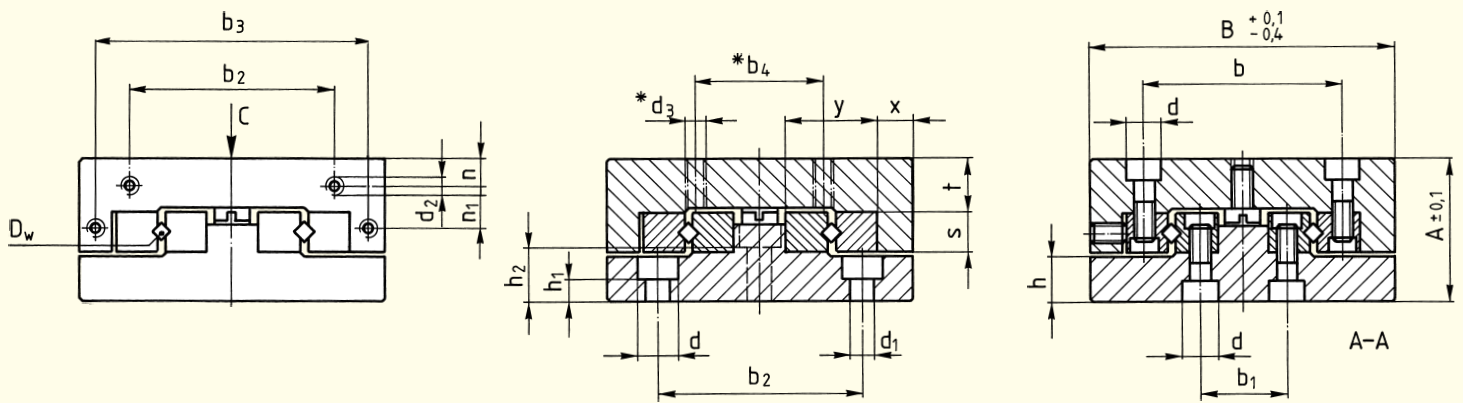

Order No.	Dimensions (mm)				L	L ₁	L ₂	*L ₃	L ₄	L ₅	*L ₆	L ₇	b	b ₁	b ₂	b ₃	*b ₄	d	d ₁	
	A	B	D _w	H																
NK 6-110				60	110	1 × 50		–		16.5										
NK 6-160				95	160	2 × 50		1 × 50		24										
NK 6-210				130	210	3 × 50		2 × 50		31.5										
NK 6-260	45	100	6	165	260	4 × 50	50	3 × 50	30	39	55	10	64	26	60	92	50	11	7	
NK 6-310				200	310	5 × 50		4 × 50		46.5										
NK 6-360				235	360	6 × 50		5 × 50		54										
NK 6-410				265	410	7 × 50		6 × 50		64										
NK 9-210				130	210	1 × 100		–		27										
NK 9-310	60	145	9	180	310	2 × 100		1 × 100	55	52	105	55	98	46	90	135	80	15	9	
NK 9-410				350	410	3 × 100	100	2 × 100		17										
NK 9-510				450	510	4 × 100		3 × 100		17										

* Only with special model B

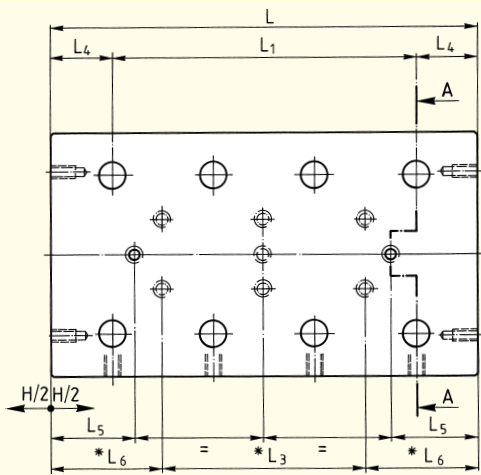

Layout of the standard attaching holes in the lower section

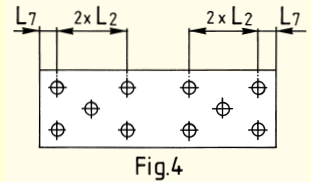
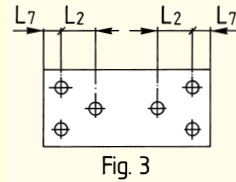
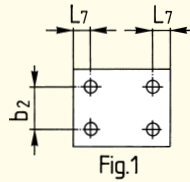

d_2	$*d_3$	h	h_1	h_2	n	n_1	s	t	x	y	C in N	M_L in Nm	M_Q in Nm	Weight in kg	Fig.
											3710	57.24	83.48	3.07	1
											5830	95.40	131.18	4.46	1
											7420	124.02	166.95	5.85	3
M4	M6	13	6	15	8	15	15	16	12	31	9540	162.18	214.65	7.24	3
											11660	200.34	262.35	8.63	3
											13250	228.96	298.13	10.02	4
											15370	267.12	345.83	11.41	4
											11700	291.20	421.20	11.8	1
M4	M8	16	7	20	11	20	22	21	14.5	44	18200	473.20	655.20	17.3	1
											20800	546.00	748.80	22.8	3
											24700	655.20	889.20	28.3	3

Ordering example: 1 Frictionless table NK 6-160 or 1 Frictionless table NK 6-160-B

3.6 Accessories

Simple Guards (-A)

against the ingress of dirt from above

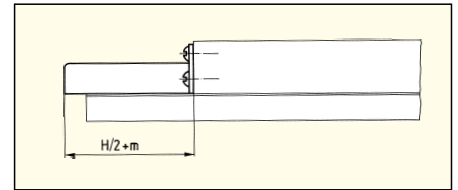

Size	1	2	3	6	9
m	2	3	4	6	11.5

4.1 Frictionless Tables Type NKL

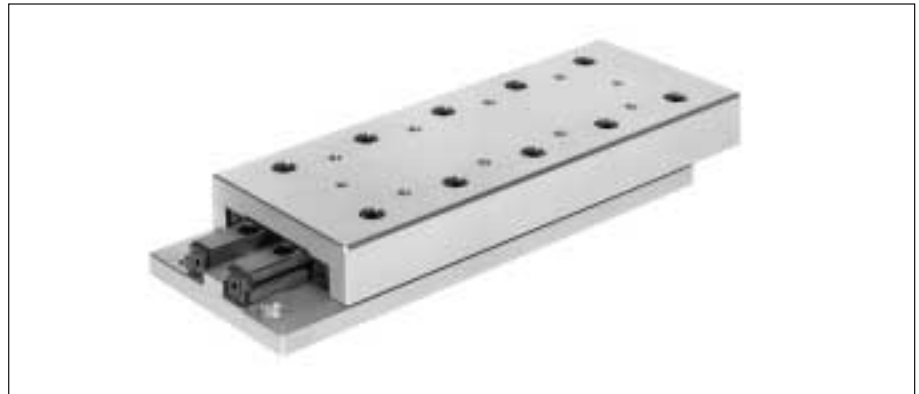

- Single axis model
- Light design, table components in aluminum
- 4 sizes
- With roller cages
- Lengths from 25 to 410 mm
- Strokes from 10 to 280 mm
- For highest accelerations available with FORMULA-S

4.2 Material

Aluminum

4.3 Standard Model

Type NKL frictionless tables consist of equal length upper and lower sections and type R linear bearings. All tables are equipped with type AC roller cages and type GB endpieces and can be mounted vertically or horizontally. In the upper and lower sections there are standardized attaching holes. The sides opposite to the setscrews in the upper and lower sections can be used for mounting purposes. For the standard model stroke limiting is made by means of two screws in the upper section and one screw in the lower section. These screws can withstand only small forces or impacts in the direction of motion and should not be used as stops.

With FORMULA-S these screws are no more necessary due to the cage assist system.

4.4 Special Model

Ball Cages Type AK (-AK)

For reduced sensitivity to dirt. Lower load carrying capacity

Roller Cages Type EE (-EE)

Plastic material, only available for size 6. Provides sealing against dirt and dust. Somewhat stiffer motion

Cage assist integrated (-KS)

for high dynamics and all assembly orientations for size 3 and 6

4.5 Specifications

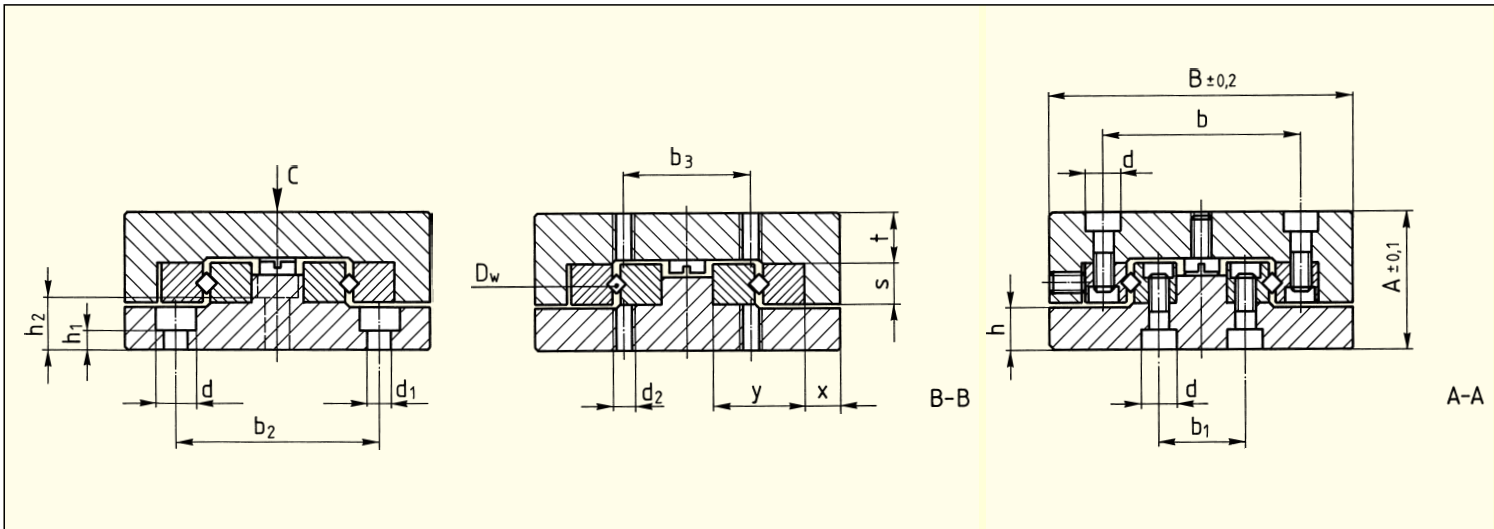

Order No.	Dimensions (mm)				L	L ₁	L ₂	L ₃	L ₄	L ₅	L ₆	L ₇	b	b ₁	b ₂	b ₃	d	
	A	B	D _w	H														
NKL 1-25				10	25	1 × 10	–			3.0								
NKL 1-35				18	35	2 × 10	1 × 10			4.5								
NKL 1-45				25	45	3 × 10	2 × 10			6								
NKL 1-55	13	30	1.5	32	55	4 × 10	10	3 × 10	7.5	7.5	12.5	3.5	18.4	8.6	22	10	4.1	
NKL 1-65				40	65	5 × 10		4 × 10		8.5								
NKL 1-75				45	75	6 × 10		5 × 10		11								
NKL 1-85				50	85	7 × 10		6 × 10		13.5								
NKL 2-35				18	35	1 × 15	–			3								
NKL 2-50				30	50	2 × 15	1 × 15			4.5								
NKL 2-65				40	65	3 × 15	2 × 15			7								
NKL 2-80	21	40	2	50	80	4 × 15	15	3 × 15	10	9.5	17.5	5	25	11	30	15	6	
NKL 2-95				60	95	5 × 15		4 × 15		12								
NKL 2-110				70	110	6 × 15		5 × 15		14.5								
NKL 2-125				80	125	7 × 15		6 × 15		17								

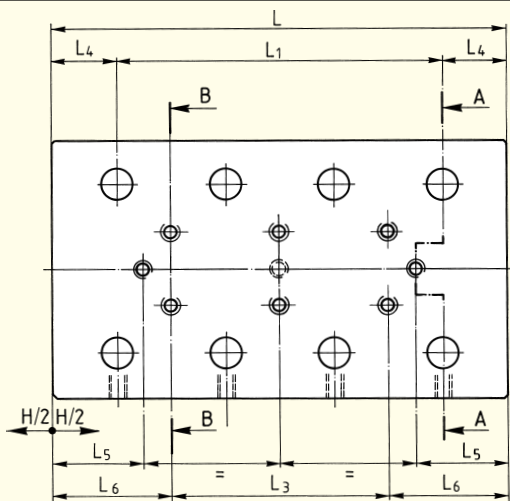

Layout of the standard attaching holes in the lower section

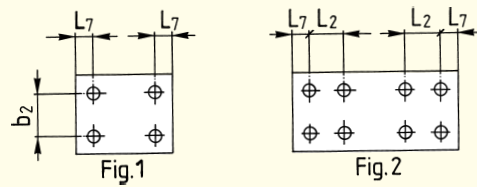

d_1	d_2	h	h_1	h_2	s	t	x	y	C in N	M_L in Nm	M_Q in Nm	Weight in kg	Fig.
2.55	M2	4.1	1.6	-	4	4.5	4	8.5	250	1.20	1.69	0.04	1
									350	1.80	2.36	0.05	1
									450	2.40	3.04	0.06	1
									550	3.00	3.71	0.075	2
									650	3.60	4.39	0.09	2
									750	4.20	5.06	0.105	2
									900	5.10	6.08	0.12	2
3.5	M3	6.7	3.2	-	6	8	5	12	425	2.72	3.83	0.11	1
									595	4.08	5.36	0.15	1
									850	6.12	7.65	0.19	1
									1020	7.48	9.18	0.23	2
									1275	9.52	11.48	0.27	2
									1445	10.88	13.01	0.31	2
									1700	12.92	15.30	0.35	2

Ordering example: 1 Frictionless table NKL 2-65

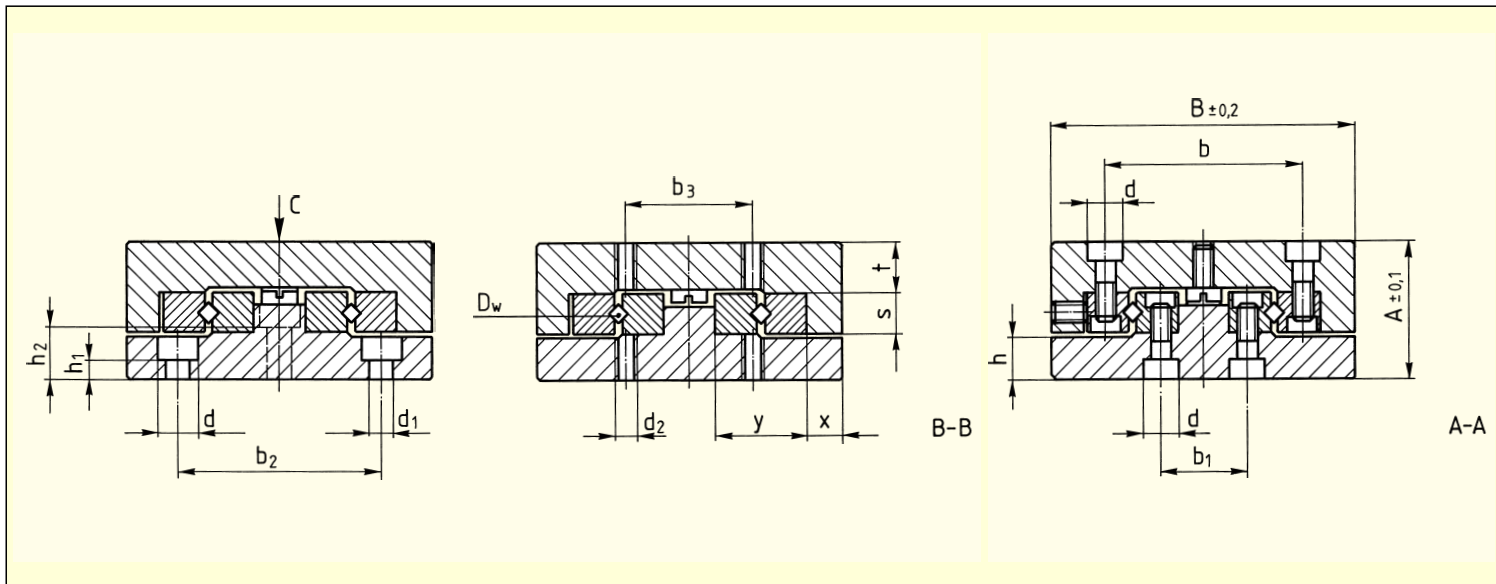

Order No.	Dimensions (mm)				L	L ₁	L ₂	L ₃	L ₄	L ₅	L ₆	L ₇	b	b ₁	b ₂
	A	B	D _w	H											
NKL 3-55				30	55	1 × 25		–		5.5					
NKL 3-80				45	80	2 × 25		1 × 25		10.5					
NKL 3-105				60	105	3 × 25		2 × 25		15.5					
NKL 3-130				75	130	4 × 25		3 × 25		20.5					
NKL 3-155				90	155	5 × 25		4 × 25		25.5					
NKL 3-180	25	60	3	105	180	6 × 25	25	5 × 25	15	30.5	27.5	10	39	17	40
NKL 3-205				130	205	7 × 25		6 × 25		30.5					
NKL 3-230				155	230	8 × 25		7 × 25		30.5					
NKL 3-255				180	255	9 × 25		8 × 25		30.5					
NKL 6-110				60	110	1 × 50		–		16					
NKL 6-160				95	160	2 × 50		1 × 50		23.5					
NKL 6-210				130	210	3 × 50		2 × 50		31					
NKL 6-260	40	100	6	165	260	4 × 50	50	3 × 50	30	38.5	55	10	64	26	60
NKL 6-310				200	310	5 × 50		4 × 50		46					
NKL 6-360				265	360	6 × 50		5 × 50		38.5					
NKL 6-410				280	410	7 × 50		6 × 50		56					

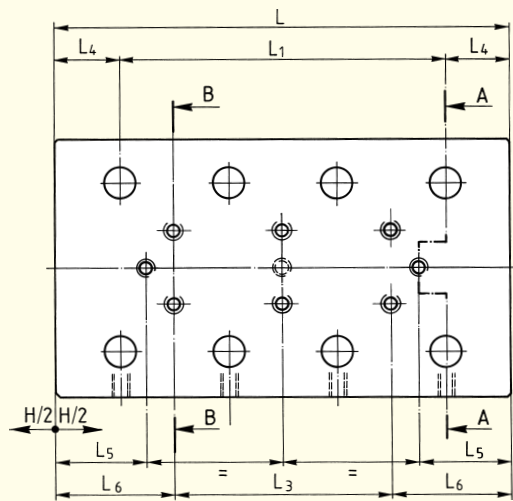

Layout of the standard attaching holes in the lower section

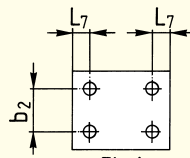

Fig.1

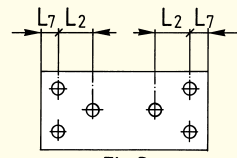

Fig.3

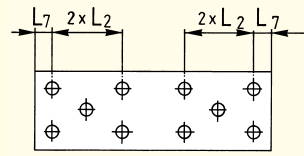

Fig.4

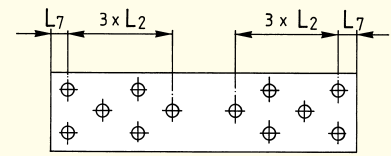

Fig.5

b_3	d	d_1	d_2	h	h_1	h_2	s	t	x	y	C in N	M_L in Nm	M_Q in Nm	Weight in kg	Fig.
											910	7.80	12.74	0.29	1
											1300	11.70	18.20	0.42	1
											1820	16.90	25.48	0.55	1
											2210	20.80	30.94	0.68	1
25	7.5	4.5	M4	8.2	3.2	7.5	8	8.5	7	18	2730	26.00	38.22	0.81	3
											3120	29.90	43.68	0.94	3
											3510	33.80	49.14	1.07	4
											3770	36.40	52.78	1.2	4
											4160	40.30	58.24	1.33	5
											3710	57.24	83.48	1.5	1
											5830	95.40	131.18	2.25	1
											7420	124.02	166.95	3	3
50	11	7	M6	11.5	4.5	12.5	15	13	12	31	9540	162.18	214.65	3.75	3
											11660	200.34	262.35	4.5	3
											12720	219.42	286.20	5.25	3
											14840	257.58	333.90	6	3

Ordering example: 1 Frictionless table NKL 6-260

5.1 Micro Frictionless Tables Type ND



- Single axis model in steel
- 3 sizes
- With roller cages
- Lengths from 25 to 155 mm
- Strokes from 12 to 90 mm
- Low friction force
- For highest accuracy requirements

5.2 Material

Steel

5.3 Standard Model

Type ND micro frictionless tables consist of equal length upper and lower sections. The double V-shaped lower section is through hardened. All sizes are equipped with type AC roller cages and can be mounted horizontally or vertically. In the upper and lower sections there are standardized attaching holes.

5.4 Special Model

Ball Cages Type AK (-AK)

For reduced sensitivity to dirt. Lower load carrying capacity

5.5 Specifications

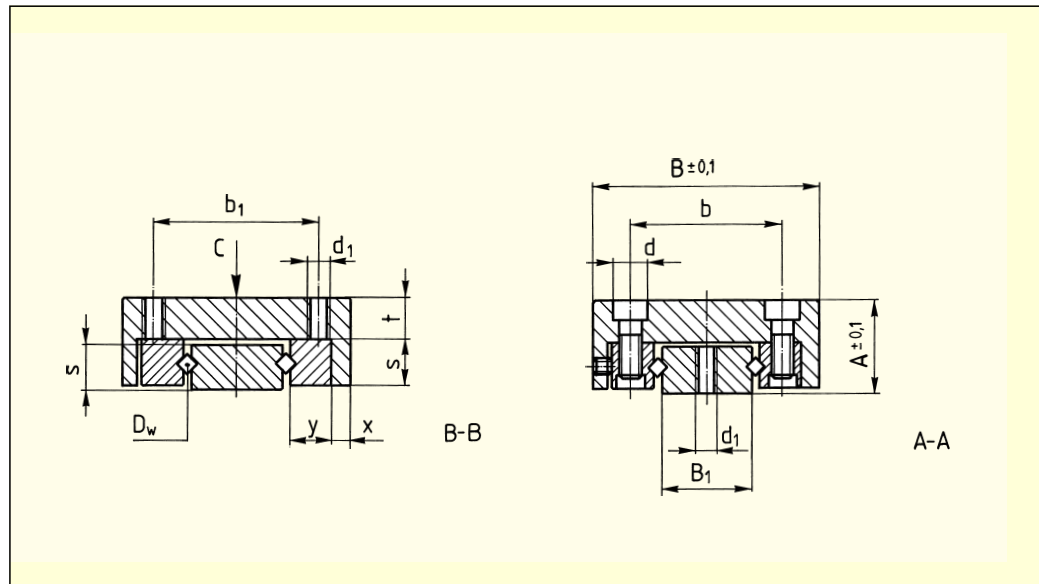

Order No.	Dimensions (mm)				H	L	L ₁	L ₂	L ₃
	A	B	B ₁	D _w					
ND 1-25.12					12	25	1 × 10		1 × 18
ND 1-35.18	8	20	7	1.5	18	35	2 × 10	7.5	1 × 28
ND 1-45.25					25	45	3 × 10		1 × 20
ND 1-55.32					32	55	4 × 10		1 × 30
ND 2-65.40					40	65	3 × 15		1 × 30
ND 2-80.50	12	30	12	2	50	80	4 × 15	10	1 × 45
ND 2-95.60					60	95	5 × 15		2 × 30
ND 3-105.60					60	105	3 × 25		1 × 50
ND 3-130.75	16	40	15	3	75	130	4 × 25	15	1 × 75
ND 3-155.90					90	155	5 × 25		2 × 50

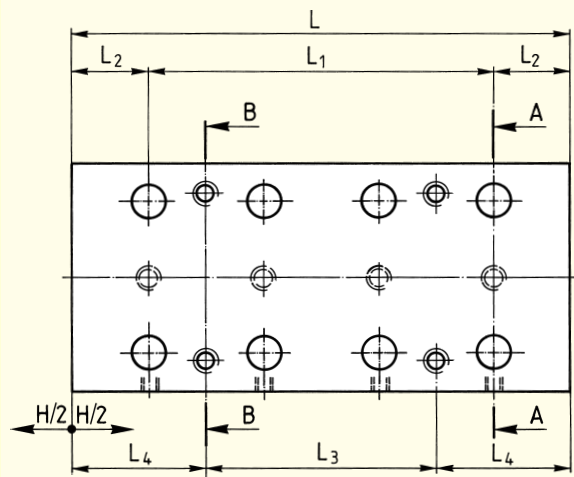

Layout of the standard attaching holes

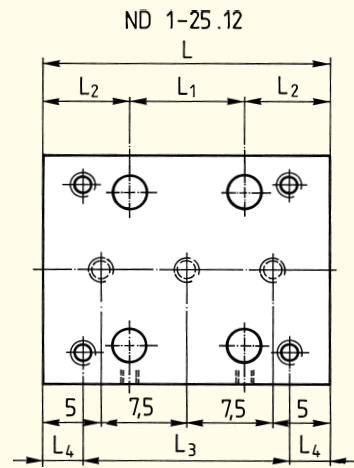

L_4	b	b_1	d	d_1	s	t	x	y	C in N	M_L in Nm	M_Q in Nm	Weight in kg
3.5									200	0.90	0.80	0.02
3.5	12.4	14	4.2	M 2.5	4	3.5	1.95	3.9	300	1.50	1.20	0.03
12.5									400	2.10	1.60	0.04
12.5									550	3.00	2.20	0.05
									765	5.44	5.16	0.16
17.5	20	22	6	M 3	6	5.5	2.3	5.5	1020	7.48	6.89	0.19
									1190	8.84	8.03	0.24
									1690	15.60	13.52	0.47
27.5	27	30	7.5	M 4	8	7.5	2.5	8.3	2210	20.80	17.68	0.59
									2730	26.00	21.84	0.70

Ordering example: 1 Micro frictionless table ND 2-80.50

6.1 Micro Frictionless Tables Type NDN



- Single axis model in corrosion resistant steel
- 3 sizes
- With ball cage in brass
- Cage centering mechanism which helps to avoid cage creep
- Length from 10 to 80 mm
- Strokes from 5 to 70 mm
- For highest accuracy requirements
- Suitable for high speed applications

6.2 Material

Corrosion resistant steel

6.3 Standard Model

The micro frictionless tables NDN consist of upper and lower parts of the same length and can be utilized horizontally or vertically. They consist of only four components; the lower and the upper part made of stainless steel, the brass cage and the stainless steel rolling elements. The U-shaped cage joins the two guideways together. As a result, the susceptibility to cage drift is essentially eliminated. NDN micro frictionless tables, preloaded in assembly to eliminate play, exhibit extremely low push force. NDN products fulfill high speed requirements with great precision and long service life.

6.4 Specifications

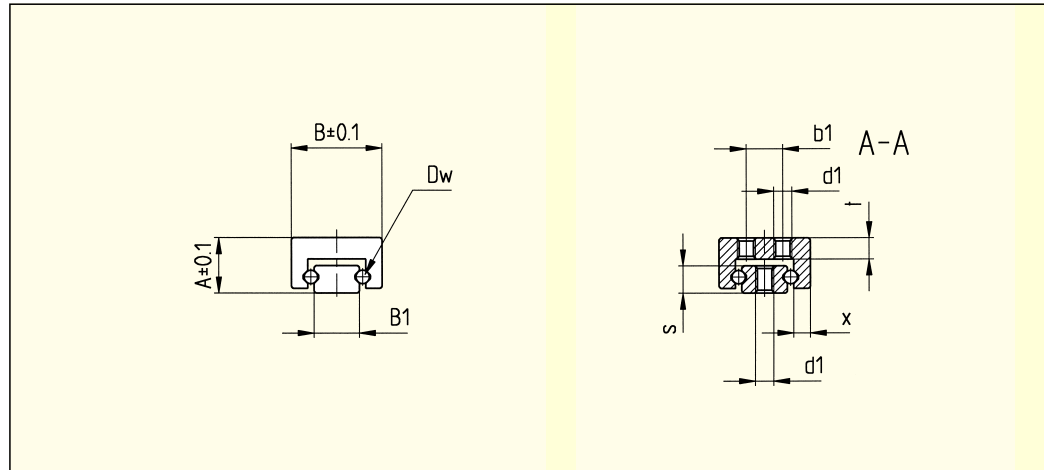

Order No.	Dimensions (mm)		B_1	D_w	H	L
	A	B				
NDN 05-10.05					5	10
NDN 05-15.10	4	7	4	1	10	15
NDN 05-20.15					15	20
NDN 05-25.20					20	25
NDN 1-15.05					5	15
NDN 1-20.10					10	20
NDN 1-25.15					15	25
NDN 1-30.20	6	10	5	1.5	20	30
NDN 1-35.25					25	35
NDN 1-40.30					30	40
NDN 1-45.35					35	45
NDN 1-50.40					40	50
NDN 2-30.20					20	30
NDN 2-40.30					30	40
NDN 2-50.40	8	15	8	2.5	40	50
NDN 2-60.50					50	60
NDN 2-70.60					60	70
NDN 2-80.70					70	80

* The calculation of the carrying capacity for NDN tables has been performed according DIN 636 part 3. A static reliability factor of 3 is taken into consideration.

Layout of the standard attaching holes in the lower- and upper section
NDN 05

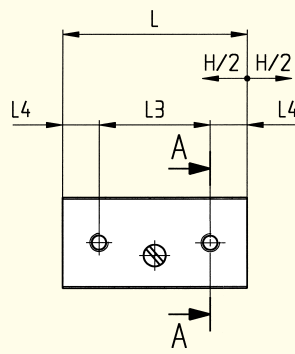
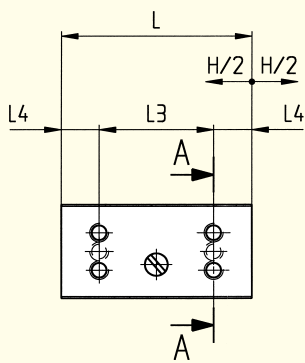

L_3	L_4	b_1	d_1	s	t	x	*C in N	M_L in Ncm	M_Q in Ncm	Weight in g
1 × 5	2.5						23	1.5	3	2
1 × 8	3.5	-	M 1.6	2.1	1.5	1.1	27	2.2	3.6	3
1 × 12	4						36	2.8	4.8	4
1 × 16	4.5						45	3.5	6	5
1 × 8	3.5						50	9	14	5
1 × 12	4						60	11	17	7
1 × 16	4.5						70	14	20	10
1 × 20	5						80	16	23	12
1 × 24	5.5	4	M 2	3	2.3	1.8	90	19	26	14
1 × 28	6						100	21	28	17
1 × 32	6.5						110	24	31	19
1 × 36	7						120	26	34	21
1 × 20	5						140	40	55	28
1 × 28	6						170	50	65	36
1 × 36	7						200	60	75	45
3 × 15	7.5	7	M 2.5	4.5	2.5	2.7	250	80	100	54
3 × 18	8						310	100	120	64
3 × 20	10						370	120	140	73

Ordering example: 1 Frictionless Table NDN 1-30.20

7.1 Acceptance Tolerances

All SCHNEEBERGER frictionless tables are manufactured as standard with the accuracies indicated in the tables. Measurement is in the unloaded state on a flat surface. The tolerance figures in the tables are for single axis.

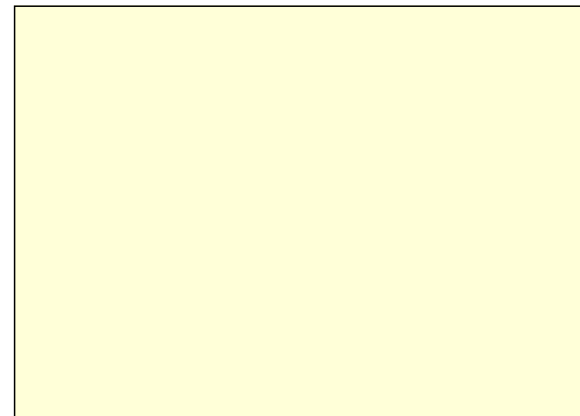

Type	L
NK	25–50
	55–100
	105–160
	165–310
	315–510
NKL	25–50
	55–100
	105–160
	165–310
	315–410
ND	25–50
	55–100
	105–155
NDN	15–30
	35–50
	60–80

7.2 Accuracy

Straightness and Flatness

The tolerance for Straightness and Flatness of travel is dependent on the various frictionless table models, the size, the length etc. This tolerance is shown above in chapter 7.1.

Closer tolerances can be supplied on request.

Parallelism

The tolerances shown in the tables are achieved by measuring the frictionless tables in the middle position. For this purpose the frictionless tables are placed unloaded on a flat surface.

Straightness of Travel in μm
over Stroke Length; Laterally

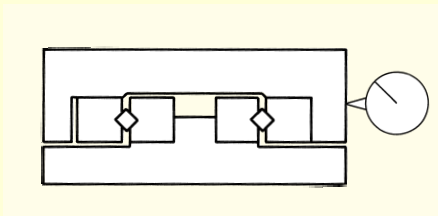

Flatness of Travel in μm
over Stroke Length; at Top

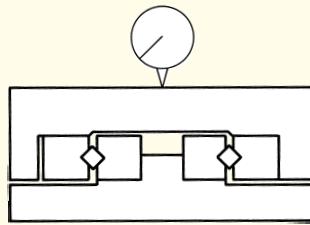

Parallelism in μm of Table Surfaces;
in Middle Position

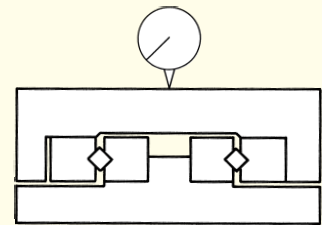

2	2	5
3	2	10
3	3	15
4	3	20
4	4	25
4	4	10
4	4	20
6	6	30
6	6	40
8	8	50
4	4	15
5	5	20
6	6	25
2	2	5
3	3	5
4	4	8

Height Tolerance

The height tolerance is $\pm 0,1$ mm.

On request, most types can be supplied in matched pairs to $\pm 0,01$ mm.

7.3 Materials

Linear Bearings and Rolling Elements

Where no contrary specifications are agreed the following are valid:

- Linear bearings material No. 1.2510 or 1.2842
- Rolling elements material No. 1.3505
- NDN material No. 1.4034

Table Bodies

Manufactured according to details under each frictionless table type.

7.4 Permissible Operating Temperatures

SCHNEEBERGER frictionless tables can be used at operating temperatures of -40° to $+80^{\circ}\text{C}$. In cases of doubt, please consult us. Please also note that temperature fluctuations in operation can have an enormous influence when positioning in the micrometer range.

7.5 Lubrication

SCHNEEBERGER frictionless tables are lubricated to protect them against corrosion and wear. The initial factory lubrication can, depending on the operating conditions, suffice for years.

Generally, bearing grease on a lithium saponified base (bearing grease KP2K per DIN 51502 respectively DIN 51825) should be used. Drip feed oiling, occasional oiling or lubricating by means of overspill oil are sufficient. To achieve the lowest rolling friction resistance, mineral base oils are recommended (CLP or HLP; viscosities of ISO VG 15 to 100 per DIN 51519). Soluble oil or coolant emulsions should, on the other hand, be kept away from the guides as they dilute or wash away the lubricant. In addition coolant emulsions tend to dry out and become tacky. Lubricants with solid base additives are also unsuitable. Lubrication intervals depend on various factors such as the loading, ambient conditions etc. Experience has shown that lubricating 2–5 times at equal intervals during the calculated operational life suffices.

7.6 Permissible Velocities and Accelerations

Under normal conditions SCHNEEBERGER frictionless tables with linear bearings with roller or ball cages can be used at velocities of up to 50 m/min.

The permissible acceleration is, in general, 50 m/s^2 . These figures can, however, be influenced substantially through the selection of the drive, the load and the length etc. In cases of doubt please consult us.

With FORMULA-S

The cage remains centered during accelerations up to 150 m/s^2 (15g) and oscillation frequencies up to 25 Hz.

7.7 Friction, Running Accuracy and Smoothness

For SCHNEEBERGER frictionless tables with roller or ball cages coefficients of friction range from 0.0005 to 0.003.

In the manufacture of SCHNEEBERGER frictionless tables the requisites for perfect running smoothness are created. SCHNEEBERGER plastic and plastic composite cages also play a large part. For successful application special care must be taken with the mounting of the frictionless tables on an adequately machined, low-deformation base.

You will find further details in the following section.

- 8.1 Horizontal and Vertical Fitting** All applications where the direction of motion is horizontal are designated horizontal fitting. All applications where the direction of motion deviates from the horizontal are designated vertical fitting.
All SCHNEEBERGER frictionless tables have preloaded anti-friction guideways and can, therefore, accept moments and forces in any direction (see also 9.2).
FORMULA-S allows all mounting orientations with no cage creep anymore.
- 8.2 Attaching Frictionless Tables** SCHNEEBERGER frictionless tables are normally attached to the base structure with standardized through holes in the base. Various models have, additionally, threaded holes which permit alternate mounting.
- 8.3 Preloading Frictionless Tables** All SCHNEEBERGER frictionless tables have playfree, preloaded antifriction guideways and can, therefore, be used without any additional measures accomplished. Preloading is by means of adjusting screws or ball selection by diameter and needs no readjustment.
- 8.4 Design of Base Unit** The advantages of SCHNEEBERGER frictionless tables are best exploited on a rigid, low-deformation, accurately machined construction. The surface quality of the supporting surfaces has no direct influence on the operation and run-out behavior of the frictionless tables. We recommend however, that they should be manufactured with a surface roughness of between N5 and N7, in order to achieve the desired planeness and parallelism tolerances.
- 8.5 Accessories for Frictionless Tables** According to the type, SCHNEEBERGER frictionless tables type NK can be supplied with accessories.
You can find the relative information under the respective frictionless table types. Should the standard accessories not meet your series production requirements, we are in a position to supply customized components.

9.1 Load Carrying Capacity and Operational Life

In applying frictionless tables, the primary consideration is the relationship of the applied load to the load carrying capacity. The elastic deformation (rigidity) must also be evaluated. The load carrying capacities of the individual frictionless tables are based on the fundamentals established by ISO and DIN for the calculation of roller bearings (ISO 281, for NDN DIN 636, part 3). The load carrying capacity C is the load with which a nominal operational life of 100 000 m travel is achieved, given that the size and direction of the load remain unchanged and the line of application is vertical onto the frictionless table surface.

By definition, the latest research results have shown that the static load should not be greater than the dynamic load. The reason for this lies in the fatigue behavior which is always initiated at the highest loaded point. In the case of an absolutely constant load during standstill and in operation, the fatigue process will start at that point where the static load is present longest. The C -values given are used in the operational life equation to calculate the operational life resulting with a given load.

The operational life is the travel in metres which is made by a frictionless table before the first signs of metal fatigue appear on any of the anti-friction guideway components. The B_{10} operational life is achieved when 90% of a statistical sample of frictionless tables meet or exceed the prescribed amount of travel.

Dynamic loading capacity C

As previously mentioned, the load carrying capacity C is based on an operational life of 100 000 m. Some manufacturers use, for various reasons, a larger load carrying capacity with 50 000 metres operational life. The C_{50} values for SCHNEEBERGER frictionless tables are calculated as follows:

$$C_{50} = C \cdot 1.23 \text{ for frictionless tables with rollers}$$

$$C_{50} = C \cdot 1.26 \text{ for frictionless tables with balls}$$

Life Expectancy

According to the DIN and ISO standards, the load carrying capacities for roller bearings are given in such a manner that from the operational life equation a value results which, with 90% probability, will be exceeded. Should this probability not suffice, then the operational life must be shortened with the a_1 factor per the following tables:

Life Expectancy %	90	95	96	97	98	99
a_1	1	0.62	0.53	0.44	0.33	0.21

Operational life calculation

The operational life L , the dynamic load carrying capacity C (N) and the loading P (N) have the following relationship:

$$L = a_1 \left(\frac{C}{P} \right)^{10/3} \cdot 10^5 \text{ m for rollers and needles}$$

$$L = a_1 \left(\frac{C}{P} \right)^3 \cdot 10^5 \text{ m for balls}$$

whereby a is the probable life expectancy factor. The operational life in hours can be calculated when the single stroke H (m) and the time needed for it t (s) are known:

$$L_h = \frac{L \cdot t}{H \cdot 3600} \text{ in h}$$

9.2 Moment Loading

In addition to the load carrying capacity C , you will find in the tables of dimensions for the individual frictionless tables the permissible values for moment loading. M_L is the maximum possible torque lengthwise and M_Q the maximum possible torque cross-wise.

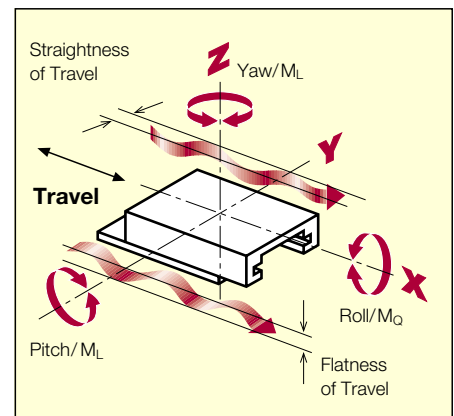

SCHNEEBERGER REPRESENTATIVES

AUSTRALIA

RJM Engineering Supplies
Tamar Street 13
VIC 3134 Ringwood
Phone +61 398 79 4881
Fax +61 398 79 3700
E-Mail: rjmeng@rjmeng.com.au

BRAZIL

IBATECH Tecnologia.Ltda.
Av. Amazonas, 974
90240-542 Porto Alegre-RS
Phone +55 51 3337 1481
Fax +55 51 3337 5265
E-Mail: ibacorp@iba-corp.com

CHINA

Servo Dynamics Co., Ltd.
12#-2-1 Chuangye Building
No. 125 Binhe Road,
Suzhou New District
215011 Jiangsu
Phone +86 (512) 6809 7576
Fax +86 (512) 6809 7690
E-Mail: info@servodynamics.com.cn

DENMARK

HERSTAD + PIPER A/S
Jernholmen 48c
2650 Hvidovre
Phone +45 36 77 4000
Fax +45 36 77 7740
E-Mail: mail@herstad-piper.dk

FINLAND

EIE Maskin Oy
PL, 80 Asematie 1
10601 Tammissaari
Phone +358 19 223 9100
Fax +358 19 223 9199

INDIA

NRB Bearings Limited Agency Division
405'A' Wing, Mittal Towers
47 (6) M.G. Road
560 001 Bangalore
Phone 080-2558 6911 / 2559 6089 /
2558 6995
Fax 080-2559 6091
E-Mail: maheshwari@nrbbearings.co.in

NRB Bearings Limited Agency Division
Office Mumbai
Dhannur,15 Sir P M Road, Fort
400 001 Mumbai
Phone 022-2266 4160 / 2266 4998
Fax 022-2266 0412 / 2267 9850
E-Mail: k.mohan@nrbbearings.co.in

Office:
Mr. Bevin Sequeira Palmyra
Plot 593-B, 21st Road
400 050 Bandra,Mumbai
Phone +91 022 2604 8831
E-Mail: bfsequeira@yahoo.co.uk

NETHERLANDS

Office:
Mr. Maurice Bastings
Beekerweg 65
NL-6235CB Ulestraten
Phone +31 (0)43 365 4532
Fax +31 (0)43 365 3579
E-Mail: info-nl@schneeberger.com

POLAND

TECHNIKA LINIOWA
ROLLICO Rolling Components
Ul. PCK 24
42-700 Lubliniec
Phone +48 34 353 0838
Fax +48 34 351 0431
E-Mail: info@rollico.com

REPUBLIC OF KOREA

Office:
Mr. Ki-Ho Kim
Kodeok 2 danji Jukong APT.261-402
Kodeok 2-dong, Kangdong-Ku
134-757 Seoul
Phone +82 2 442 0971
Fax +82 2 442 2971
E-Mail: khkim@schneeberger.com

LIATO Korea Inc.
12-15, Moonhyung-Ri, Opo-Eup
Kwangjoo-City
464-894 Kyonggi-Do
Phone +82 31 766 1434(6)
Fax +82 31 766 1438
E-Mail: imwos@kornet.net

Lubo Industries Ltd.
640-12, Gojan-Dong
Namdong-Ku
Incheon
Phone +82 32 821 5656
Fax +82 32 821 9501
E-Mail: luboinc@luboinc.co.kr

NUMACS Corporation Ltd.
Rm303, Namdong building, 987-11
Mansu-dong, Namdung-ku
405-204 Incheon
Phone +82 32 461 8110
Fax +82 32 461 8112
E-Mail: casypark@unitel.co.kr

INTECH Automation Inc.
FL 13,94-46, Youngdeungpo 7-Ga
Youngdeungpo-Ku
150-037 Seoul
Phone +82 2 2632 6770
Fax +82 2 2632 6880
E-Mail: intech01@kornet.net

SINGAPORE

Servo Dynamics
Kaki Bukit Road 1 No. 10
#01-30 Kaki Bukit Park
416175 Singapore
Phone +65 6844 0288
Fax +65 6844 0070
E-Mail: servodynamics@servo.com.sg

SLOVAKIA

LINEATECH, s.r.o.
ul. Puste c. 861
013 22 Rosina
Phone +421 41 500 5177
Fax +421 41 500 5178
Mobile +421 905 253721
E-Mail: sukala@lineatech.sk

SOUTH AFRICA

Fischli & Fuhrmann Ltd.
P.O.Box 253
1600 Isando Transval
Phone +27 11 974 5571
Fax +27 11 974 5574
E-Mail: info@fifu.co.za

Office:
Mr. Mike Owen
LIATO S A (PTY) LTD
513 Marine Drive
4052 Durban
Phone +27 31 467 179
Fax +27 31 467 0179
E-Mail: mike@liato.co.za

SWEDEN

EIE Maskin AB
Box 13031
402 51 Goeteborg
Phone +46 31 707 4800
Fax +46 31 195 255
E-Mail: eie@eie.se

TAIWAN

Ever Bright Precision Ltd.
1F, no. 52, Lane 10
Phone +886 2 2659 5586
Fax +886 2 2659 5587
E-Mail: sales@everbright.com.tw

TURKEY

Office:
BIRLIK RULMAN PAZ.LTD.STI.
Kemeralti Cad. No:20
80030 Karakoy-Istanbul
Phone +90 212 249 5495
Fax +90 212 244 2140
E-Mail: birlik@birlikrulman.com

